

(19) World Intellectual Property Organization  
International Bureau



(43) International Publication Date  
25 May 2001 (25.05.2001)

PCT

(10) International Publication Number  
WO 01/36567 A1

- (51) International Patent Classification<sup>7</sup>: C10K 1/02, 1/18
- (21) International Application Number: PCT/US00/06340
- (22) International Filing Date: 8 March 2000 (08.03.2000)
- (25) Filing Language: English
- (26) Publication Language: English
- (30) Priority Data:  
09/443,975 19 November 1999 (19.11.1999) US
- (71) Applicant: ENERGY PROCESS TECHNOLOGIES, INC. [US/US]; P.O. Box 582707, Tulsa, OK 74158 (US).
- (72) Inventors: MCQUIGG, Kevin; 6440 S. 221 E. Ave., Broken Arrow, OK 74014 (US). SCOTT, W., N.; 1223 South Indian, Tulsa, OK 74127 (US).
- (74) Agent: MCKAY, Molly, D.; 3207 East 22nd Street, Tulsa, OK 74114-1823 (US).
- (81) Designated States (*national*): AE, AL, AM, AT, AU, AZ, BA, BB, BG, BR, BY, CA, CH, CN, CR, CU, CZ, DE, DK, DM, EE, ES, FI, GB, GD, GE, GH, GM, HR, HU, ID, IL, IN, IS, JP, KE, KG, KP, KR, KZ, LC, LK, LR, LS, LT, LU, LV, MA, MD, MG, MK, MN, MW, MX, NO, NZ, PL, PT, RO, RU, SD, SE, SG, SI, SK, SL, TJ, TM, TR, TT, TZ, UA, UG, UZ, VN, YU, ZA, ZW.
- (84) Designated States (*regional*): ARIPO patent (GH, GM, KE, LS, MW, SD, SL, SZ, TZ, UG, ZW), Eurasian patent (AM, AZ, BY, KG, KZ, MD, RU, TJ, TM), European patent (AT, BE, CH, CY, DE, DK, ES, FI, FR, GB, GR, IE, IT, LU, MC, NL, PT, SE), OAPI patent (BF, BJ, CF, CG, CI, CM, GA, GN, GW, ML, MR, NE, SN, TD, TG).
- Published:**  
— With international search report.
- For two-letter codes and other abbreviations, refer to the "Guidance Notes on Codes and Abbreviations" appearing at the beginning of each regular issue of the PCT Gazette.*

(54) Title: PROCESS FOR THE REMOVAL OF PARTICULATES AND AEROSOLS FROM A GAS STREAM

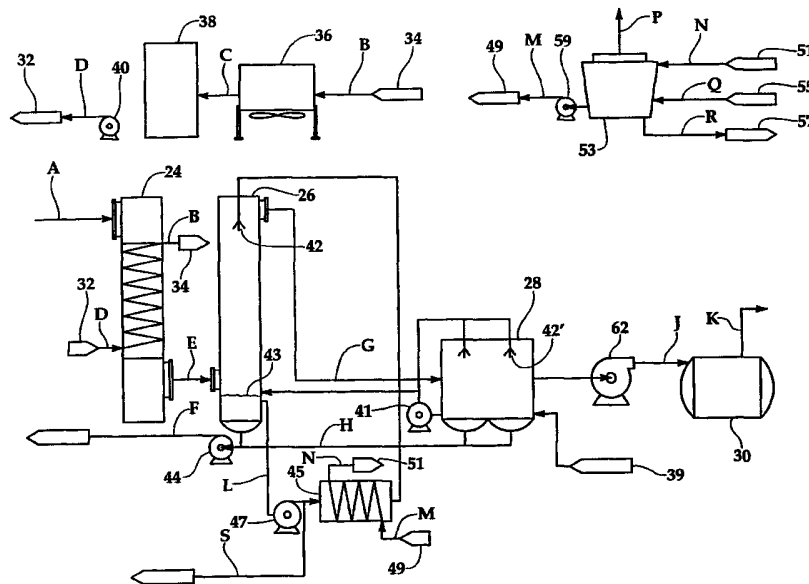

(57) Abstract: The present invention is a method for removing particulate matter and aerosols from a gas stream generated by gasification prior to the gas stream being used as fuel in an internal combustion device or as synthesis gas for subsequent processing. The present invention consists of first cooling the gas stream, then oil scrubbing it to further cool it and to remove particulates and some tars, and finally passing the gas stream through one or more vortex chambers (28) to remove additional tars. Each vortex chamber (28) employs a high-speed fan (46) that forces the tar droplets against the interior wall (50) of the vortex chamber (28) where the tar coalesces and is removed.



WO 01/36567 A1

## PROCESS FOR THE REMOVAL OF PARTICULATES AND AEROSOLS FROM A GAS STREAM

**BACKGROUND OF THE INVENTION****1. Field of the Invention**

5           The present invention relates to a process for removing particulate and aerosol droplets from a stream of gases. More specifically, the present invention relates to a process for removing entrained particles and droplets of tar from a gas stream originating from a source such as a biomass gasifier so that the resulting cleaned gas stream is suitable fuel for operating an internal  
10 combustion device, such as an engine or turbine, which may be coupled to an electrical generator or can be utilized as a synthetic gas for subsequent processing. For the purposes of simplicity, an internal combustion device is discussed herein.

**15 2. Description of the Related Art**

          Developing countries need decentralized sources of power, i.e. power systems for each remote community. In developing countries, where natural gas, petroleum products, or coal are not readily available to remote communities and hydropower is not possible, communities often have some  
20 local form of biomass that could serve as an energy source if that biomass could be converted to electrical power. Locally available forms of biomass might include rice straw or rice hulls, sugar cane bagasse, poultry litter, refuse, paper plant pulp sludge, switchgrass, waste resulting from extraction of olive oil

from olives, peanut shells, sawdust or wood chips, wood bark, municipal solid waste, coconut shells, corn cobs, cotton stover, etc.

Industrialized nations have a heightened awareness of the environmentally deleterious effects of the production of "greenhouse gases" including carbon dioxide produced by the combustion of fossil fuels. Many nations have agreed to aggressively reduce their production of these "greenhouse gases" by encouraging the use of alternate, renewable energy such as biomass. A concurrence of nations was reached during the summit conference on the environment that was held in Kyoto, Japan several months ago.

Technology is currently available for converting biomass materials, by heating the biomass materials under starved oxygen conditions, to a gas stream that has sufficient heating value to operate an internal combustion device, i.e. in the range of 125 to 250 BTUs per standard cubic foot, depending on the biomass materials being processed. The resulting gas stream contains nitrogen, carbon dioxide, trace amounts of carry-over ash and tar, and calorific constituents of carbon monoxide, hydrogen, and some alkanes and alkenes. Gasification is recognized worldwide as an innovative method of converting biomass into energy.

However, one of the problems that has been experienced with converting biomass to energy is that the gas stream that is produced by gasification units is contaminated with particulate matter and with aerosol droplets of tar that can foul an internal combustion device unless they are efficiently removed from the gas stream prior to introducing the gas stream into

the device. Currently there is not an economical method for effectively removing the entrained particulate matter and the aerosol droplets of tar from these types of gas streams. The reason that the particulate matter and aerosol droplets of tar can not be easily be removed from the gas stream is that a large  
5 portion of the particles and droplets are micron to sub-micron in size and are not effectively removed by traditional gas scrubbing processes.

The present invention addresses this problem by combining an indirect gas cooler, a direct contact spray scrubber chamber followed by one or more enhanced vortex chambers. To achieve the desired cleanliness in the resulting  
10 gas stream, it may be necessary to employ two or more vortex chambers in series. The indirect gas cooler is a shell and tube heat exchanger that cools the gas stream from the gasifier by indirect heat exchange with a cooling medium such as air or water. The direct contact spray scrubber employs a liquid hydrocarbon, such as used motor oil, to scrub out the particulate matter  
15 and some of the organic aerosols that are entrained in the gas stream as the gas stream passes through the direct contact spray scrubber.

Once the gas exits the direct contact spray scrubber, it enters the enhanced vortex or vortices. Each enhanced vortex chamber employs a high-speed fan to propel the remaining entrained droplets of tar against the inside  
20 surface of the vortex chamber along with additional oil. When the droplets of tar hit the oil coated inside surface of each vortex chamber, the droplets coalesce on the surface. The tar and oil mixture then gravity flows out of each vortex chamber, thereby removing the tar from the gas stream. The gas stream, having thus been cleaned of its particulate and aerosol impurities, then

enters a low-pressure surge tank. If the gasifier is operating a pressure less than atmospheric pressure, an induced draft fan may be employed to convey the gas through the system. From here, the gas stream can be sent directly to the internal combustion device for mixing with combustion air so that it can be

5 burned in such internal combustion device, such as an engine or turbine, which may be coupled to an electrical generator or can be utilized as a synthetic gas for subsequent processing.

### SUMMARY OF THE INVENTION

The present invention is a method for removing particulate matter and aerosols from a gas stream generated by a biomass gasification unit. The present invention consists of first cooling the gas stream, then oil scrubbing it to  
5 remove particulate matter and some tars and to further reduce the temperature of the gas stream, and finally passing the gas stream through one or more vortex chambers to remove additional tars.

The gas stream is first passed through an indirect gas-cooling vessel to reduce the temperature of the gas stream to a temperature that will not crack  
10 petroleum scrubbing liquor, i.e. a temperature below approximately 600 degrees Fahrenheit. If the gas stream is cooled below 450 degrees Fahrenheit, tars may condense in the indirect gas-cooling vessel thereby restricting gas flow. Therefore, the most desirable temperature range is between 450 and 600 degrees Fahrenheit. Cooling of the gas stream is  
15 necessary since the gas exits the gasification unit at a high temperature, i.e. approximately 1200-1500 degrees Fahrenheit. The gas stream must be cooled to a temperature that will not crack petroleum products, such as the motor oil, since the gas stream will come in contact with the petroleum scrubbing liquor when it enters the next vessel in the process, i.e. a direct contact spray  
20 scrubber. The gas-cooling vessel employs indirect heat exchange with air or water to cool the gas stream to an acceptable temperature. To minimize gas flow restriction from impurity accumulation, the minimum heat exchanger tubing size should not be less than 2 inch.

Upon leaving the gas-cooling vessel, the gas stream enters a direct  
25 contact spray scrubber. The direct contact spray scrubber employs a liquid

hydrocarbon, such as used motor oil, to directly scrub the gas stream and remove the particulate matter, some of the organic aerosols, and some water that is entrained in the gas stream. Within the direct contact spray scrubber, a petroleum product or oil, such as used motor oil, is sprayed into the gas stream

5 countercurrent to the direction of flow of the gas stream to scrub out particulate matter and some of the tar droplets contained in the gas stream. Some of the excess water also is removed by condensation in the direct contact spray scrubber since the temperature of the gas stream falls below the water vapor dew point within the direct contact spray scrubber. This water condensation

10 occurs around sub-micron particle seed that promotes particle growth. The enlarged particles are more effectively removed in the downstream, enhanced vortex chamber or chambers. The gas stream exits the direct contact spray scrubber at a temperature of approximately 150 degrees Fahrenheit.

Upon exiting the direct contact spray scrubber, the gas stream enters an

15 enhanced vortex chamber or chambers, if more than one vortex chamber is employed. Here the gas stream is mechanically scrubbed of tar. Additional motor oil is sprayed into the gas stream as the gas stream enters each vortex chamber. The oil and gas stream mixture enter each vortex chamber adjacent to or beneath a high-speed fan that propels the gas stream, oil, and entrained

20 droplets of tar against the inside surface of the vortex chamber. It is believed that the vortex created by the rapidly rotating fan forms a low-pressure zone. Within this low-pressure zone, tars with a partial vapor pressure in excess of the zone pressure condense. It is further believed that the maximum fan tip speed for the high-speed fan is approximately M.P.H. since fan tip speeds in

25 excess of this speed may result in metal fatigue of the fan blades.

When the droplets of tar contact the inside surface of the vortex chamber, they adhere to the oil-coated surface and coalesce with the oil on the surface. The oil also impinges on the fan blades and serves to keep the blades cleaned of tar that might otherwise accumulate. The temperature of the gas stream is approximately 100 degrees Fahrenheit when it initially enters the first vortex chamber and is approximately 125 degrees Fahrenheit when it exits the last vortex chamber. The increase in temperature of the gas stream as it passes through the vortex chamber or chambers is due to the heat of compression.

Because the temperature of the interior of each vortex chamber is above the pour point temperature, the tar will flow down the wall of each vortex chamber into a sump and can be disposed of via a tar pump that connects to the sump of each vortex chamber.

Upon leaving the vortex chamber or chambers, the gas stream is sufficiently free of particulate matter and tar that it can be burned in an internal combustion device without fouling or can be subsequently processed. Any residual particulate matter or hydrocarbon aerosols contained in the gas stream at this point are sub-micron in size and are not sufficient to cause any deterioration in extended operation of down stream equipment.

Prior to introduction of the cleaned gas stream into down stream equipment, the gas stream will enter a low-pressure surge tank. If the gasifier is operating at less than atmospheric pressure, an induced draft fan conveys the gas through the system and into the surge tank. The surge tank is sized in residence time to provide gas mixing, compensating for fluctuations in the gasification process. Also the surge tank serves as a final knock out drum for



8

removal of any remaining liquids from the gas stream. The temperature of the gas stream as it enters the surge tank is approximately 110-150 degrees Fahrenheit. From the surge tank, the gas stream flows to an internal combustion device or to subsequent processing.

5

**BRIEF DESCRIPTION OF THE DRAWINGS**

FIGURE 1 is a flow diagram showing a gasifier employing equipment downstream of the gasifier that cleans the gas stream according to a preferred method of the present invention.

FIGURE 2 is an enlarged portion of the diagram from Figure 1, showing the equipment employed to clean the gas stream according to the present invention.

FIGURE 3 is a side view of a vortex chamber employed in the present invention.

FIGURE 4 is a top plan view of the vortex chamber shown in Figure 3.

## DETAILED DESCRIPTION OF THE PREFERRED EMBODIMENT

### The Invention

Referring now to the drawings and initially to Figure 1, there is illustrated a gasifier **20** that employs a method according to a preferred method of the present invention for cleaning a gas stream generated by the gasifier **20**. Box 5 **22** and box **22A** illustrate the process of the present invention in Figure 1. Box **22A** shows the auxiliary cooling equipment for the process that is illustrated in box **22** and is also a part of the invention. Figure 2 shows an enlargement of the contents of boxes **22** and **22A** from Figure 1.

10 The present invention is a method for removing particulate matter and aerosols from a gas stream generated by a gasifier **20**. As shown in box **22**, the present invention consists of first cooling the gas stream in an indirect gas cooler **24**, then oil scrubbing the gas stream in a direct contact spray scrubber **26** to remove particulate matter, some tars and heat from the gas stream, and 15 the finally passing the gas stream through one or more vortex chambers **28** that are provided in series to remove additional tars before the gas stream passes to a low pressure surge tank **30**. For clarity, hereafter the vortex chambers **28** will be described in the singular tense, with the understanding that the singular tense also includes the plural tense since more than one vortex chamber **28** 20 may be used in series in the invention.

As indicated by line **A**, the gas stream flows from the gasifier **20** to the indirect gas cooler **24**. The indirect gas cooler **24** is an indirect heat exchanger and the gas stream is cooled as it passes through the indirect gas cooler **24**. The most desirable temperature range for the gas stream as it exits the indirect

gas cooler **24** is between 450 and 600 degrees Fahrenheit. Cooling of the gas stream is necessary since the gas exits the gasifier **20** at a high temperature, i.e. approximately 1200-1500 degrees Fahrenheit. The gas stream must be cooled to a temperature, i.e. generally below 600 degrees Fahrenheit, that will not crack petroleum scrubbing liquor, such as motor oil, since the gas stream will encounter petroleum scrubbing liquor when it enters the next vessel in the process, i.e. a direct contact spray scrubber **26**. However, the gas should not be cooled below approximately 450 degrees Fahrenheit as tars may condense in the indirect gas cooler, thereby restricting flow. Although the indirect gas cooler **24** is hereafter described as employing water as the cooling medium, air may alternately be employed as the cooling medium.

To minimize gas flow restriction from impurity accumulation, the minimum heat exchanger tubing size should not be less than 2 inch.

Still referring to Figures 1 and 2, numeral **32** indicates lower temperature cooling water entering the indirect gas cooler **24** and numeral **34** indicates higher temperature cooling water leaving the indirect gas cooler **24**. As illustrated by line **B** in the upper left corner of Figure 1, after exiting the indirect gas cooler **24**, the higher temperature cooling water **34** flows to an air cooled heat exchanger **36** where the water **34** is cooled to form the lower temperature cooling water **32**. This lower temperature cooling water **32** then flows, as illustrated by line **C**, into a cooling water surge tank **38** where it remains until a cooling water pump **40** again pumps it to the indirect gas cooler **24**, as illustrated by line **D**.

As shown by line **E**, upon leaving the indirect gas cooler **24**, the gas stream enters a direct contact spray scrubber **26**. The direct contact spray scrubber **26** employs a liquid hydrocarbon **42**, such as used motor oil or other suitable oil, to directly scrub the gas stream and remove from the gas stream  
5 the particulate matter, some of the organic aerosols or tars, and some water that is entrained in the gas stream.

Within the direct contact spray scrubber **26**, the liquid hydrocarbon **42** is sprayed into the gas stream, preferably countercurrent to the direction of flow of the gas stream as illustrated in the drawings, to scrub out particulate matter  
10 and some of the tar droplets contained in the gas stream. Some excess water also is removed from the gas stream in the direct contact spray scrubber **26** since the temperature of the gas stream falls below the water vapor dew point within the direct contact spray scrubber **26**, thereby allowing some of the water to condense and drop out of the gas stream. This water condensation occurs  
15 around sub-micron particle seeds which promotes particle growth. The enlarged particles are more effectively removed in the down stream enhanced vortex chamber.

Still referring to Figures 1 and 2, numeral **42** indicates lower temperature liquid hydrocarbon scrubbing liquor entering the direct contact spray scrubber  
20 **26** and numeral **43** indicates higher temperature liquid hydrocarbon scrubbing liquor leaving the direct contact spray scrubber **26**. As illustrated by line **L**, after exiting the direct contact spray scrubber **26**, oil recirculating pump **47** pumps the higher temperature liquid hydrocarbon scrubbing liquor **43** to the recirculating oil cooler **45**. Also as illustrated by line **S**, it may be necessary to

periodically blow down some of the higher temperature liquid hydrocarbon scrubbing liquor **43** and condensed water as liquid blow down to maintain the quality of the scrubbing liquor.

As indicated by line **M**, cooling water **49** enters the recirculating oil cooler **45** where it picks up heat from the high temperature liquid hydrocarbon through indirect heat transfer and then exits the recirculating oil cooler **45** as hot cooling water **51**. As shown in the upper right hand corner of Figures 1 and 2 by line **N**, the hot cooling water **51** exits the recirculating oil cooler **45** and flows to a cooling tower **53** where excess heat is lost to the atmosphere, as shown by line **P**, thereby converting the hot cooling water **52** back to the cooling water **49** suitable for recirculation to the recirculating oil cooler **45**. Line **Q** illustrates that makeup water **55** is added to the cooling tower as needed to maintain the necessary volume in the cooling tower and line **R** illustrates that blow down **57** is removed from the cooling tower as needed to maintain proper water chemistry. Line **M** shows that the cooling water **49** is pumped back to the recirculating cooler **45** by employing a water recirculating pump **59**.

Spent liquid hydrocarbon scrubbing liquor **43**, with included tar and particulate matter that has been removed from the gas stream in the direct contact spray scrubber **26**, is pumped by a tar blow down pump **44** back to the gasifier **20** as tar and ash blow down that becomes a part of the feedstock to the gasifier **20**, as illustrated by line **F**. The gas stream exits the direct contact spray scrubber **26** at a temperature of approximately 150 degrees Fahrenheit or less.

As indicated by line **G**, upon exiting the direct contact spray scrubber **26**, the gas stream enters the enhanced vortex chamber **28**. Here the gas stream is mechanically scrubbed of almost all of the remaining entrained tar and any residual particulate matter. A small amount of additional liquid hydrocarbon **42'**, such as for example motor oil, is sprayed into the gas stream as the gas stream enters the vortex chamber **28**.

As shown, the additional liquid hydrocarbon **42'** is recirculated through the vortex chamber **28** via oil recirculating pump **41** and fresh oil **39** is added to the vortex chamber **28** as make up for the liquid hydrocarbon **42'**.

Referring now also to Figures 3 and 4, the oil and gas stream mixture enters the vortex chamber **28** adjacent to or beneath a high-speed fan **46**. The fan **46** has rotating fan blades **48** that propels the gas stream, oil, and entrained droplets of tar against the inside surface **50** of the vortex chamber **28**. It is believed that the vortex created by the rapidly rotating fan forms a low-pressure zone. Within this low-pressure zone, tars with a partial vapor pressure in excess of the zone pressure condense. It is further believed that the maximum fan tip speed for the high-speed fan **46** is approximately 300 M.P.H. since fan tip speeds in excess of this speed may result in metal fatigue and cause failure of the fan blades **48**.

When the droplets of tar contact the inside surface **50** of the vortex chamber **28**, they adhere to the liquid hydrocarbon **42'** coating the inside surface **50** and the droplets coalesce. The liquid hydrocarbon **42'** also impinges on the fan blades **48** and serves to keep the blades **48** cleaned of tar that might otherwise accumulate. The temperature of the gas stream is

approximately 100 degrees Fahrenheit when it enters the vortex chamber **28** and is approximately 125 degrees Fahrenheit when it exits the vortex chamber **28**. The increase in temperature of the gas stream as it passes through the vortex chamber **28** is due to the heat of compression.

5           Because the temperature of the interior of the vortex chamber **28** is above the pour point temperature of the tar, the tar flows down the walls of the vortex chamber **28** with the liquid hydrocarbon **42'** into a bottom or sump **52** of the vortex chamber **28**. The mixture is disposed of via the tar blow down pump **44** that connects to the sump **52** of the vortex chamber **28** and pumps the tar  
10           and spent liquid hydrocarbon **42'** to the gasifier **20**, as shown by line H and by previously described line F. The flow of the gas stream through the vortex chamber **28** is illustrated in Figures 3 and 4 by the arrows.

          Referring now to Figure 3, the internal structure of the vortex chamber **28** is illustrated. The gas stream enters the vortex chamber **28** adjacent or  
15           below the blades **48** of the high-speed fan **46**. A fan motor **54** that connects to the fan **46** via a fan belt **56** powers the fan **46**. The fan blades **48** are oriented so that they force the gas stream outward against the inside surface **50** of the vortex chamber **28**.

          An inverted cone shape deflector **58** is provided within the vortex  
20           chamber **28** immediately below the fan **48**. The inverted cone shaped deflector **58** lies within a cone shaped portion **60** of the vortex chamber **28** that is located below the fan **46**. There is a space between the edges of the deflector **58** and the inside surface **50** of the cone shaped portion **60** of the vortex chamber **28**. The clean gas stream passes through the space and into the bottom **61** of the



vortex chamber **28** before exiting the vortex chamber **28**. The deflector **58** directs the mixture of tar and liquid hydrocarbon **42'** that falls on the deflector **58** onto the inside surface **50** of the cone shaped portion **60** of the vortex chamber **28**. From here, the mixture of tar and liquid hydrocarbon **42'** runs  
5 down the inside surface **50** to the bottom or sump **52** of the vortex chamber **28**. A portion of the liquid hydrocarbon accumulation is recirculated via external pump **41**. Spent liquid hydrocarbon and tar are pumped back to the gasifier **20** via the tar blow down pump **44**, as previously described.

As illustrated by line **J** in Figures 1 and 2, the clean gas stream exits the  
10 vortex chamber **28** into the low-pressure surge tank **30**. If the gasifier is operating a less than atmospheric pressure, an induced draft fan **62** conveys the gas from the vortex chamber **28** and into the surge tank **30**. The surge tank is sized in residence time to provide gas mixing, compensating for fluctuations in the gasification process. The surge tank **30** also serves as a final knock out  
15 drum for final removal of liquids from the gas stream. Line **K** illustrates the clean gas stream flowing from the low-pressure surge tank **30**.

Upon leaving the vortex chamber **28**, the gas stream is sufficiently free of particulate matter and tar that it can be burned as fuel in an internal combustion device or can be utilized as synthetic gas for subsequent  
20 processing. Any residual particulate matter contained in the gas stream at this point is sub-micron in size. Tar passing through the vortex chamber **28** is not sufficient to cause any deterioration in extended operation of down stream equipment. The temperature of the gas stream as it exits the surge tank **30** is approximately 110-150 degrees Fahrenheit.

While the invention has been described with a certain degree of particularity, it is manifest that many changes may be made in the details of construction and the arrangement of components without departing from the spirit and scope of this disclosure. It is understood that the invention is not  
5 limited to the embodiments set forth herein for the purposes of exemplification, but is to be limited only by the scope of the attached claim or claims, including the full range of equivalency to which each element thereof is entitled.

**WHAT IS CLAIMED IS:**

- 1           1.     A method for removing particulate and aerosol contaminants from  
2                     a gas stream originating from a negative or near atmospheric  
3                     pressure gasifier comprising the following steps:
- 4                     a.     cooling the gas stream in a indirect gas cooler to  
5                             approximately 600 degrees Fahrenheit or below,
- 6                     b.     liquid scrubbing the gas stream by directly contacting the  
7                             gas stream with liquid hydrocarbon to remove particulate  
8                             matter from the gas stream, to remove some of the aerosol  
9                             tars contained in the gas stream, to condense some water  
10                            vapor and to further cool the gas stream to approximately  
11                            100 degrees Fahrenheit, and
- 12                    c.     mechanically scrubbing the gas stream by forcefully  
13                            directing the gas stream against an inside surface of one  
14                            or more vortex chambers to cause the remaining aerosol  
15                            tars to coalesce on the inside surface and thereby be  
16                            removed from the gas stream.
- 1           2.     A method for removing particulate and aerosol contaminants from  
2                     a gas stream according to Claim 1 wherein an additional amount

3 of liquid hydrocarbon is mixed with the gas stream as the gas  
4 stream enters each vortex chamber in step c.

1 3. A method for removing particulate and aerosol contaminants from  
2 a gas stream according to Claim 1 wherein the indirect gas cooler  
3 is a heat exchanger employing water or air as a cooling medium  
4 to cool the gas stream.

1 4. A method for removing particulate and aerosol contaminants from  
2 a gas stream according to Claim 1 wherein a high speed fan  
3 provided in each vortex chamber is employed to forcefully  
4 directing the gas stream against the inside surface of the vortex  
5 chamber.

1 5. A method for removing particulate and aerosol contaminants from  
2 a gas stream according to Claim 4 wherein the high speed fan is  
3 rotated so that the fan blade tip speed is approximately 300  
4 M.P.H.

1 6. A method for removing particulate and aerosol contaminants from  
2 a gas stream according to Claim 1 further comprising the  
3 following step that occurs after step c:

- 4           d.     conveying the gas stream via an induced draft fan and into  
5                     a low-pressure surge tank from which the gas stream is  
6                     removed to be used as a fuel or for further processing.
- 1           7.     A method for removing particulate and aerosol contaminants from  
2                     a gas stream originating from a pressurized gasifier comprising  
3                     the following steps:
- 4                     a.     passing a gas stream through a gas cooler to cool the gas  
5                             stream to approximately 600 degrees Fahrenheit or below,
- 6                     b.     passing the gas stream through a direct contact spray  
7                             scrubber to liquid scrub the gas stream with liquid  
8                             hydrocarbon to remove particulate matter from the gas  
9                             stream, to remove some of the aerosol tars contained in  
10                            the gas stream, to condense some water vapor, and to  
11                            further cool the gas stream, and
- 12                    c.     passing the gas stream through one or more vortex  
13                            chambers that forcefully direct the gas stream against an  
14                            inside surface of each vortex chamber causing the  
15                            remaining aerosol tars to coalesce on the inside surface of  
16                            each vortex chamber and be removed from the gas  
17                            stream.

- 1        8.     A method for removing particulate and aerosol contaminants from  
2             a gas stream according to Claim 7 wherein an additional amount  
3             of liquid hydrocarbon is mixed with the gas stream as the gas  
4             stream enters each vortex chamber is step c.
- 1        9.     A method for removing particulate and aerosol contaminants from  
2             a gas stream according to Claim 7 wherein the indirect gas cooler  
3             is a heat exchanger employing water as a cooling medium to cool  
4             the gas stream.
- 1        10.    A method for removing particulate and aerosol contaminants from  
2             a gas stream according to Claim 7 wherein a high speed fan  
3             provided in each vortex chamber is employed to forcefully  
4             directing the gas stream against the inside surface of the vortex  
5             chamber.
- 1        11.    A method for removing particulate and aerosol contaminants from  
2             a gas stream according to Claim 10 wherein the high speed fan is  
3             rotated so that the fan blade tip speed is approximately 300  
4             M.P.H.

- 1        12.    A method for removing particulate and aerosol contaminants from  
2            a gas stream according to Claim 7 further comprising the  
3            following step that occurs after step c:
- 4            d.        passing the gas stream into a low-pressure surge tank  
5            from which the gas stream is removed to be used as a fuel  
6            or for further processing.

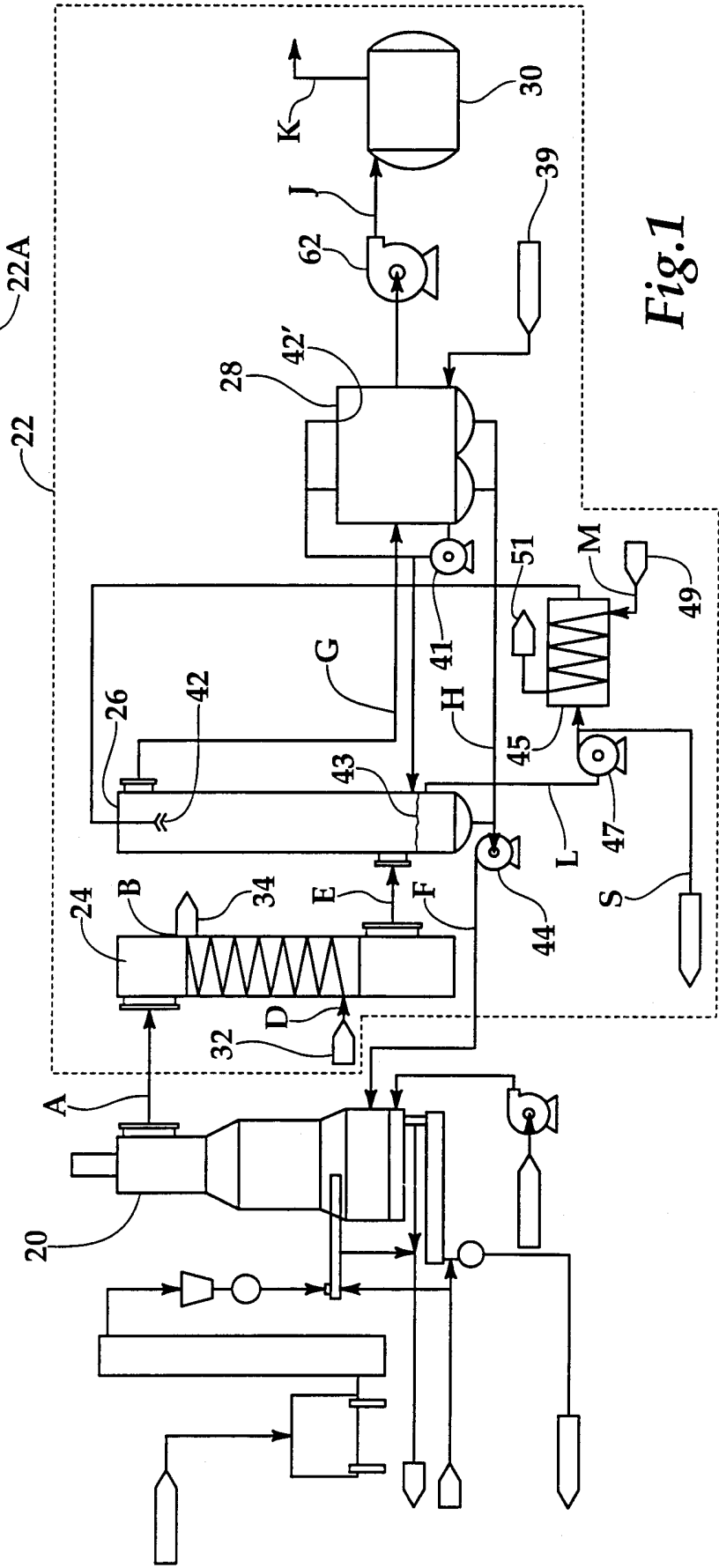
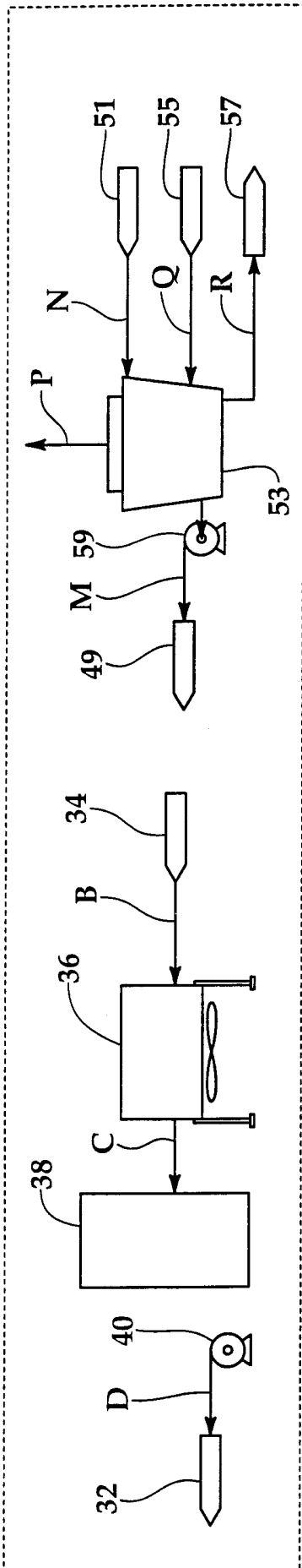

Fig.1



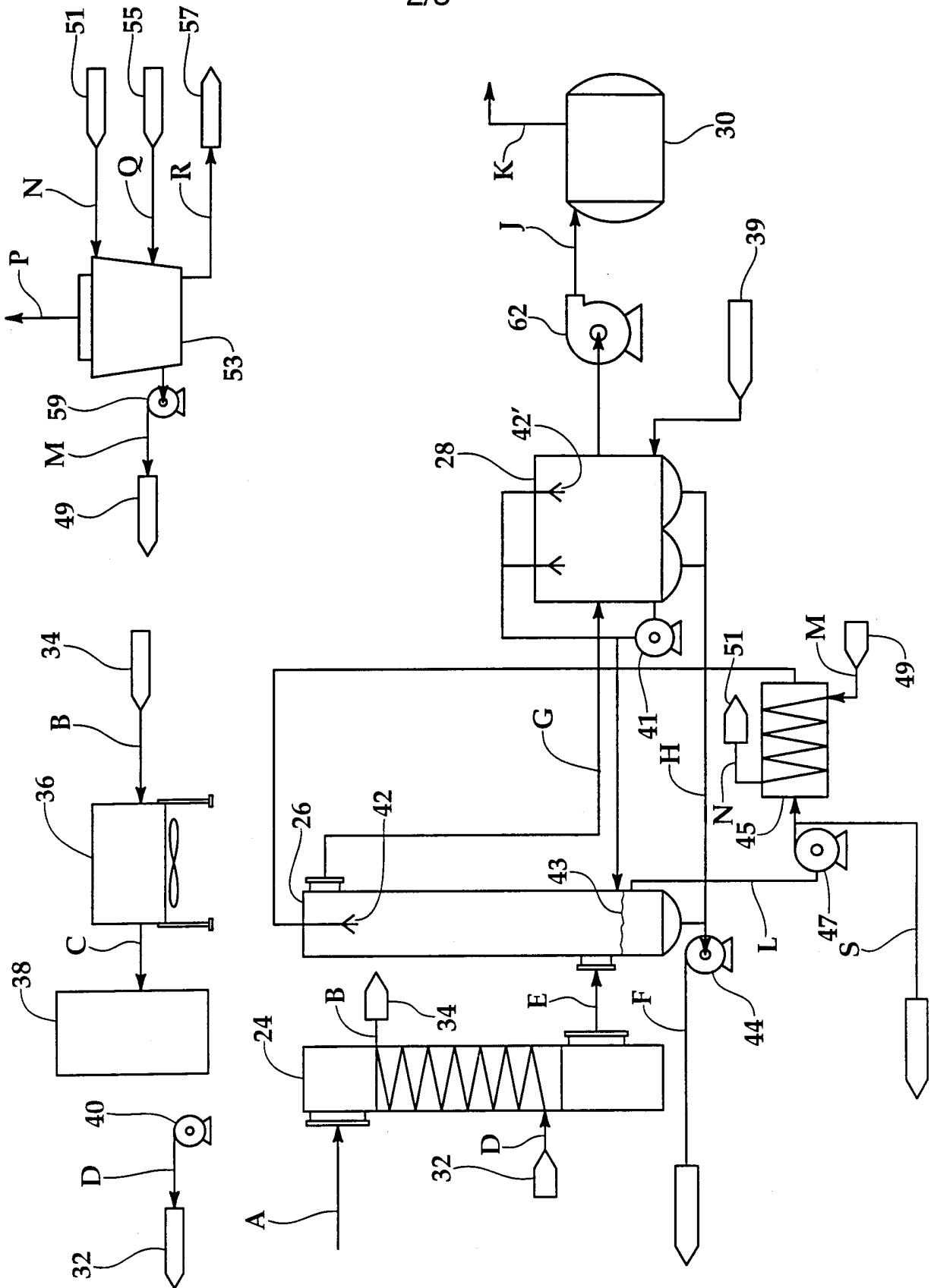

Fig.2

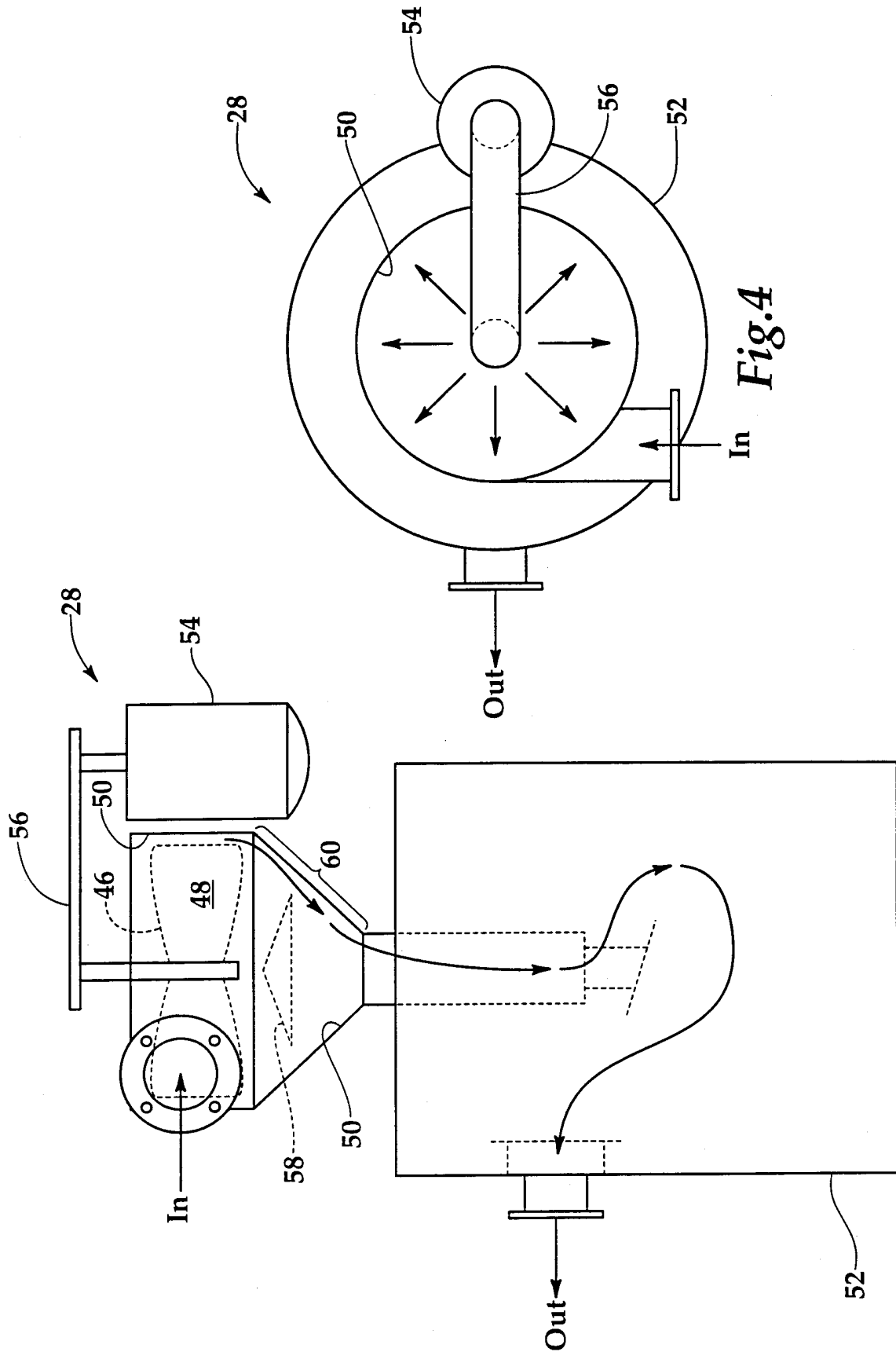

Fig. 4

Fig. 3

# INTERNATIONAL SEARCH REPORT

International Application No  
PCT/US 00/06340

**A. CLASSIFICATION OF SUBJECT MATTER**  
IPC 7 C10K1/02 C10K1/18

According to International Patent Classification (IPC) or to both national classification and IPC

**B. FIELDS SEARCHED**

Minimum documentation searched (classification system followed by classification symbols)  
IPC 7 C10K

Documentation searched other than minimum documentation to the extent that such documents are included in the fields searched

Electronic data base consulted during the international search (name of data base and, where practical, search terms used)

**C. DOCUMENTS CONSIDERED TO BE RELEVANT**

Category °	Citation of document, with indication, where appropriate, of the relevant passages	Relevant to claim No.
A	DE 195 29 536 A (VER VERWERTUNG UND ENTSORGUNG) 13 February 1997 (1997-02-13) ---	
A	GB 1 520 041 A (HOELTER H) 2 August 1978 (1978-08-02) ---	
A	DD 109 658 A (G SCHOLZ) 12 November 1974 (1974-11-12) -----	

Further documents are listed in the continuation of box C.

Patent family members are listed in annex.

° Special categories of cited documents :

- "A" document defining the general state of the art which is not considered to be of particular relevance
- "E" earlier document but published on or after the international filing date
- "L" document which may throw doubts on priority claim(s) or which is cited to establish the publication date of another citation or other special reason (as specified)
- "O" document referring to an oral disclosure, use, exhibition or other means
- "P" document published prior to the international filing date but later than the priority date claimed

- "T" later document published after the international filing date or priority date and not in conflict with the application but cited to understand the principle or theory underlying the invention
- "X" document of particular relevance; the claimed invention cannot be considered novel or cannot be considered to involve an inventive step when the document is taken alone
- "Y" document of particular relevance; the claimed invention cannot be considered to involve an inventive step when the document is combined with one or more other such documents, such combination being obvious to a person skilled in the art.
- "&" document member of the same patent family

Date of the actual completion of the international search

10 July 2000

Date of mailing of the international search report

17/07/2000

Name and mailing address of the ISA

European Patent Office, P.B. 5818 Patentlaan 2  
NL - 2280 HV Rijswijk  
Tel. (+31-70) 340-2040, Tx. 31 651 epo nl,  
Fax: (+31-70) 340-3016

Authorized officer

Polesak, H

# INTERNATIONAL SEARCH REPORT

Information on patent family members

International Application No

PCT/US 00/06340

Patent document cited in search report	A	Publication date	Patent family member(s)	Publication date
DE 19529536	A	13-02-1997	NONE	
GB 1520041	A	02-08-1978	DE 2504839 A	19-08-1976
			DE 2508666 A	09-09-1976
			DE 2509667 A	16-09-1976
			DE 2509733 A	23-09-1976
			DE 2509789 A	16-09-1976
			DE 2509947 A	09-09-1976
			DE 2519487 A	18-11-1976
			DE 2528525 A	30-12-1976
			AU 499917 B	03-05-1979
			AU 1082576 A	11-08-1977
			CA 1057936 A	10-07-1979
			FR 2300126 A	03-09-1976
			JP 51090303 A	07-08-1976
			US 4123502 A	31-10-1978
			US 4206186 A	03-06-1980
			ZA 7600353 A	26-01-1977
DD 109658	A	12-11-1974	NONE	