

April 7, 1970

E. J. HOFFMAN

3,505,204

DIRECT CONVERSION OF CARBONACEOUS MATERIAL TO HYDROCARBONS

Filed April 10, 1967

2 Sheets-Sheet 1

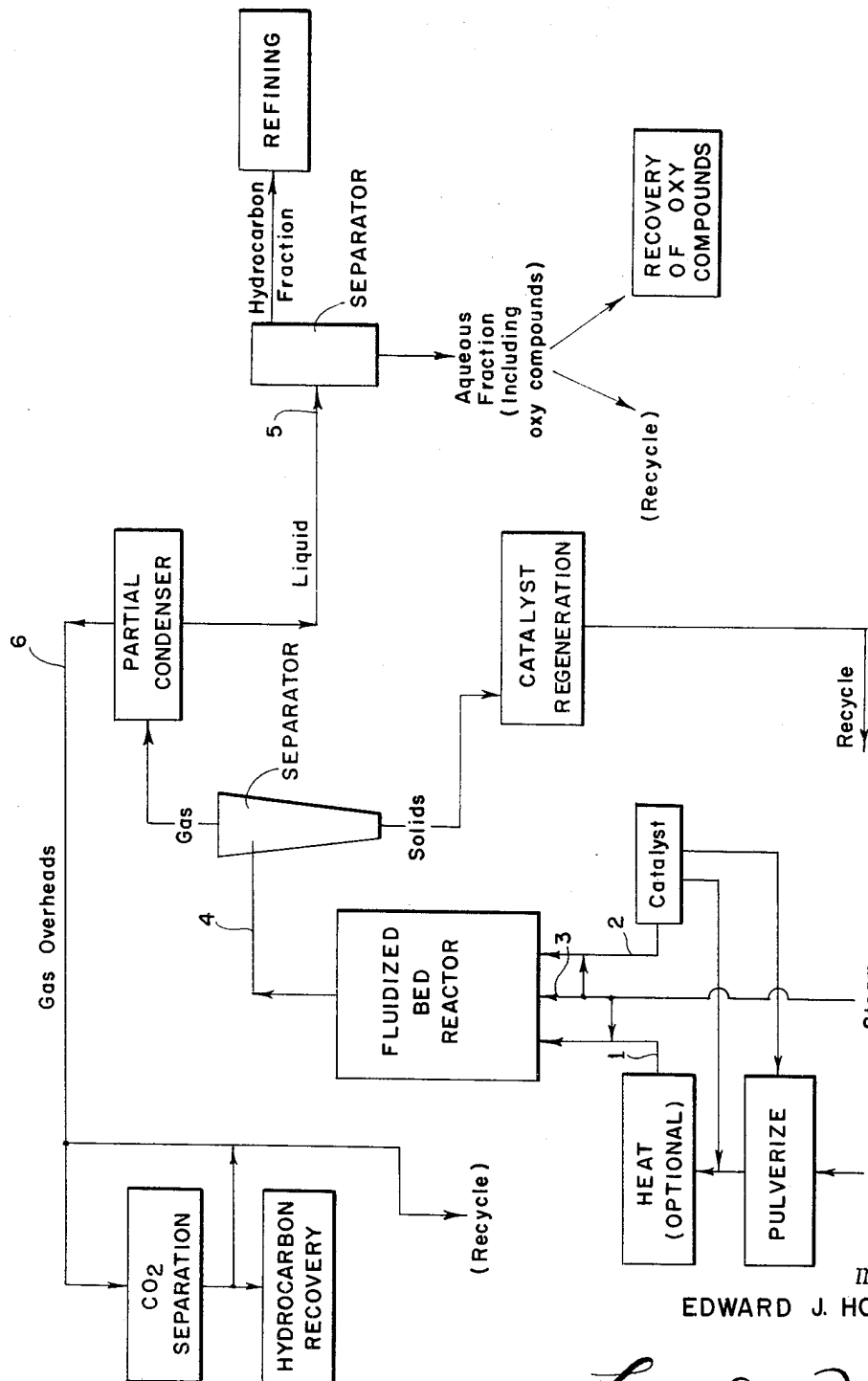

FIG. 1

INVENTOR
EDWARD J. HOFFMAN

BY *Larson and Taylor*

ATTORNEYS

April 7, 1970

E. J. HOFFMAN

3,505,204

DIRECT CONVERSION OF CARBONACEOUS MATERIAL TO HYDROCARBONS

Filed April 10, 1967

2 Sheets-Sheet 2

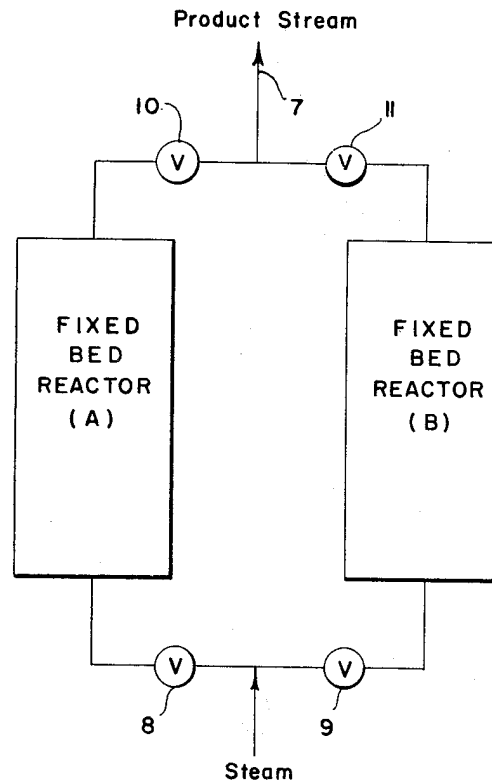

FIG. 2

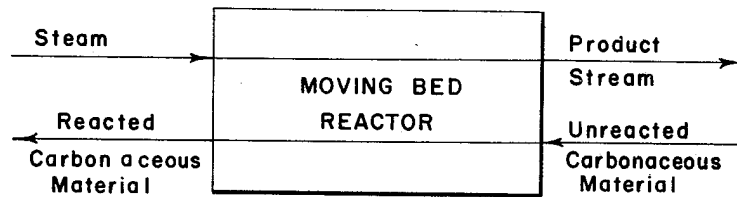

FIG. 3

INVENTOR
EDWARD J. HOFFMAN

BY *Larson and Taylor*

ATTORNEYS

1

3,505,204

DIRECT CONVERSION OF CARBONACEOUS MATERIAL TO HYDROCARBONS

Edward J. Hoffman, Laramie, Wyo., assignor to The University of Wyoming, a body corporate of Wyoming

Filed Apr. 10, 1967, Ser. No. 629,498

Int. Cl. C10g 1/08

U.S. Cl. 208—10

16 Claims

ABSTRACT OF THE DISCLOSURE

Coal or other naturally occurring bituminous carbonaceous materials, or carbon, coke, or carbonaceous petroleum materials are converted directly to hydrocarbons and oxygen-containing organic compounds by reacting the carbonaceous material with steam in the presence of a two-component catalyst system. The first catalyst component is a compound of an alkali or alkaline earth metal and the second component is a compound of a group 8 transition metal. By utilizing these catalysts, good yields of hydrocarbons are obtained in a single stage reaction at temperatures of from 800 to 1000 or 1200° F.

The present invention relates to methods of converting carbonaceous materials to hydrocarbons. More particularly, the invention relates to a method of directly converting carbonaceous materials to hydrocarbons by reaction with steam. Still more particularly, the invention relates to methods of directly converting materials such as coal and naturally occurring carbonaceous materials to hydrocarbons and oxygen-containing organic materials in a one-stage reaction with steam.

The desirability of converting coal and other hydrogen-deficient carbonaceous materials to hydrocarbons has long been recognized. It has been recognized, for example, that economical conversion of cheap carbonaceous materials to relatively expensive organics such as gasoline would be a significant achievement in view of the vast deposits of such carbonaceous materials such as oil shale and oil sands. In the past, efforts toward the chemical conversion of carbonaceous materials, as exemplified by coal, have been directed to two principal methods: direct and indirect hydrogenation.

In direct hydrogenation, the coal is reacted with hydrogen at moderate to severe conditions of temperature and pressure. The product is determined by the reaction conditions, catalyst, and space velocity or residence time. Processing may be batch or continuous. Direct hydrogenation of coal was accomplished as early as 1913. Ordinarily a liquid carrier is used to contain the coal (and catalyst), and the carrier participates in and modifies the hydrogenation reactions. While direct hydrogenation has been applied commercially, the expense of hydrogen and the rather severe operating conditions have been serious problems.

Indirect hydrogenation refers to the production of a synthesis gas from coal (or other sources) followed by the reaction of the synthesis gas over a suitable catalyst to form hydrocarbons as well as oxygenated organic compounds.

The synthesis gas which is produced by the reaction of the carbonaceous material and steam, consists of a mixture of carbon monoxide and hydrogen of varying proportions, which also influences the nature of the product. The reaction of the synthesis gas to hydrocarbons is generally called the Fischer-Tropsch reaction. Reaction conditions are considerably less severe than for direct hydrogenation.

The production of synthesis gas may be performed by any of the several conventional water gas processes, in

2

which coal (carbon) and steam react by the water gas reaction to produce water gas, an equimolar mixture of hydrogen and carbon monoxide: $C + H_2O \rightarrow CO + H_2$. The percentage hydrogen may be increased by adding steam and passing the mixture over a suitable catalyst to yield more hydrogen by the water gas shift:

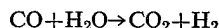

In this way virtually all hydrogen can be produced for use in, say, direct hydrogenation. Synthesis gas (and also hydrogen, via the CO-shift) is also produced from natural gas (essentially methane) by steam reforming or partial oxidation.

The production of synthesis gas from coal is a high temperature endothermic reaction requiring the addition of a good deal of heat to sustain the reaction. This has led to several means for contributing heat to the reaction. Cyclic processes air-oxidize the bed of coal to a suitable temperature level, then introduce steam. Continuous processes generally introduce pure oxygen in the proportions to sustain the reaction temperature. All means contribute considerably to the expense.

The reaction of synthesis gas is a low temperature exothermic reaction giving off heat. This requires that heat be removed from the reacting system, which contributes greatly to the cost, especially since a catalyst is involved. Chiefly for cost reasons, hydrocarbon products produced by direct or indirect hydrogenation from coal and other carbonaceous materials have not been economically competitive with petroleum-derived products.

It is an object of the present invention to provide a process for the direct conversion of carbonaceous materials into hydrocarbons. It is a further object of the invention to provide such a process widely applicable to carbonaceous materials such as naturally occurring carbonaceous deposits, and other carbon-containing materials such as carbon, coke, petroleum fractions, etc., capable of hydrogenation. It is still a further object of the invention to provide an economical process of the type mentioned and to such processes which are applicable to the carbonaceous materials either in situ in their naturally deposited state or in a reactor. It is still a further object of the invention to provide such methods which are operable under relatively mild operating conditions and which yield hydrocarbons and/or oxygenated organic compounds in good yield. These and other objects which will become apparent in view of the detailed description following are achieved according to the invention by reacting the carbonaceous material with steam in the presence of a two-component catalyst system to be described more fully in the detailed description which follows and which includes the drawings wherein:

FIGURE 1 is a flow sheet diagram of a method according to the invention utilizing a fluidized bed reactor; and

FIGURES 2 and 3 are diagrams of alternative types of reactors.

By the use of a suitable two-component catalyst system according to the invention, it is possible to reduce the temperature levels of the initial carbon steam reaction to those for the Fischer-Tropsch reactions, thus making possible the direct, single stage overall conversion with the attendant savings in investment and processing costs. The endothermicity of the initiation reactions tends to be balanced by the exothermicity of the completion reaction, thus eliminating most of the heat transfer problems ordinarily encountered.

In this process, carbonaceous material and steam are reacted in a single stage reactor. A multiple catalyst is also present in the reactor, and can be introduced pulverized or in a slurry. The reactor is operable in the tempera-

ture range of approximately 800–1200° F., and at pressures of from near atmospheric to around 500 p.s.i., depending upon the nature of the product desired. The overhead product from the reactor is passed through a solid-gas separator to remove entrained solids, and then partially condensed to yield a hydrocarbon phase and an aqueous phase containing predominately the oxygenated compounds, though some are also partitioned in the hydrocarbon phase. The uncondensed vapors contain the more volatile hydrocarbons (principally methane, ethane, etc.), as well as carbon dioxide.

The gaseous product may be treated for CO₂ and H₂S removal and processed for LPG (liquified petroleum gas, usually propane and butane) and for recovery of any gasoline fractions also present. The sulfur content will vary depending upon the coal used. The gases may be partly recycled to the reactor (before or after CO₂ recovery) as a means of suppressing gas formation and for reactor temperature control.

The condensed hydrocarbon liquid phase may be further refined according to conventional refinery procedures to yield gasoline and diesel fuels, and higher molecular weight residues. Some gas and LPG will also be dissolved in the liquid layer, depending upon the phase equilibria of the separation. The aqueous layer will contain principally dissolved oxygenated compounds such as the lower alcohols, aldehydes and ketones, and organic acids. These may be subjected to further separation by means of the techniques of azeotropic and extractive distillation, solvent extraction, etc. The aqueous layer can be recycled as a source of steam for the reaction and fluidization. If all or part of the oxygenated compounds are left in the recycle, these compounds will act to suppress further oxy formation.

The catalyst system includes two components. The first component is a compound of an alkali metal or an alkaline earth metal. Oxides and carbonates of sodium and potassium are preferred, but other compounds, such as chlorides, hydroxides, sulfates, silicates, sulfides, etc., can be used. The compounds can be used directly in an impure state. For example, the hydrated sodium carbonate ore, trona, can be used directly. The second catalyst is a Fischer-Tropsch type catalyst containing a transitional metal of group 8 of the Periodic Table. Compounds of iron, nickel and cobalt are preferred, and of these, iron compounds, particularly the iron oxides, are the most preferable. Other metals belonging to the group are Ru, Rh, Pd, Os, Ir and Pt. The compounds may be oxides or other compounds such as carbonates, nitrates, carbides, chlorides, sulfates, etc., and the second component may include compounds of metals in different valence states. For example, the second component may comprise ferrous and ferric oxide. The second component need not be pure. Iron catalyst, for example, may consist of nitrated steel wool, steel turnings, iron ore, roasted pyrites, fused iron, mill scale, iron alloys, steel shot, lathe turnings, magnetite, hematite, Luxmasse, Lautamasse, siderite, goethite, ferrosilicon, limonite, and sandstone (with Fe present). The more active catalysts for the completion of the reaction would be Ni or Co. However, these are not only more expensive than Fe, but are quite reactive at the reactor conditions, and tend to produce gases (greater degree of hydrogenation) preferentially to liquids. The nickel and cobalt will also tend to be lost from the system due to the production of volatile carbonyls.

The first and second catalyst components may each comprise one or more of the mentioned compounds and, it is preferred that the second component comprise tow similar compounds, such as oxides, of the same metals, but at different valence states. The relative amount of each component can vary widely. Generally speaking, however, the system will contain from 5 to 75% by weight of the first component and preferably about 10 to 50%.

The carbonaceous material, steam and catalyst system are brought together in a reaction zone which may be provided in situ in a natural deposit of carbonaceous material or in a reactor. Several types of reactors, such as a fixed bed or moving bed type can be used, but a fluidized bed reactor is preferred. The amount of steam provided for reaction can vary widely depending on desired results. Higher steam to carbon ratios cause a greater amount of hydrogenation and production of more lower molecular weight compounds. However, generally speaking, the ratio of steam to carbon, on a weight basis will ordinarily be between 1/4 and 5/1 and preferably between 1/2 and 3/1.

The temperature of the reaction is maintained at 800 to 1200° F., preferably 800 to 1000° F. The temperature is conveniently maintained by introducing superheated steam to the reaction zone. Higher temperatures increase the yield, but favors the production of gaseous and lower molecular products and oxy compounds. The steam can be superheated to any suitable extent to provide extra heat as necessary for the process. Excess steam can be utilized to provide the same effect. In all of the processes according to the invention, excess steam has a beneficial distilling effect. Excess heat can also be provided by the addition of oxygen to the reaction and this is particularly useful in the in situ reaction. The steam temperature is conveniently between 800° F. and 1400° F. or higher. The steam temperature will ordinarily be in excess of 1000° F., particularly in the in situ process.

The pressure can vary widely. Pressures of under 200 p.s.i. are preferred, but higher pressures of up to 500 p.s.i. are feasible. Pressures of over 300 p.s.i. favor the production of lower molecular weight hydrocarbons. Lower pressures favor the production of hydrocarbons, but reduce conversion or require the use of more catalysts to obtain good yield. Substantially atmospheric pressure is necessarily utilized in an in situ operation but a minimum pressure of about 15 p.s.i. is preferred for reactor operations to achieve good yield and catalyst economy. By operating at pressures of from 15 to 30 p.s.i. conventional petroleum processing equipment can be utilized and practical yields obtained.

The carbonaceous materials to which the invention is applicable vary widely in nature and composition. However, it can be generally said that the carbonaceous material is hydrogen deficient and thus capable of being hydrogenated to hydrocarbons. The principal materials occur in natural deposits, but the invention is also applicable to carbonaceous products such as carbon, coke and petroleum fractions. The naturally occurring carbonaceous deposits to which the invention is applicable include fossil fuels such as peat, coal, gilsonite, oil shale, oil or tar sands and other natural deposits of bituminous material including very low grade materials combined with substantial amounts of inerts. Coals of any grade, such as lignite, bituminous and anthracite, are readily hydrogenated according to the invention.

Where a reactor is utilized, the carbonaceous material may be pulverized and/or heated prior to effecting the reaction with steam. Preheating helps to maintain efficient reactor temperature conditions and is particularly effective where the carbonaceous material contains a substantial amount of water. Since the reaction requires bringing together steam and carbonaceous material, reducing the particle size or the carbonaceous material is obviously desirable. Where the reactor is of the fixed or moving bed type, substantially any size material can be used. In a fluidized system, the particle size can vary widely, between limits of practical fluidizing requirements known as such to those of ordinary skill in the art. Generally speaking, however, the carbonaceous material in fluidized bed reactors will be between 200 Tyler mesh and 1/2 inch. The size of the catalyst particles are scaled to the carbonaceous material size according to Stokes

law calculations and can vary quite widely from theoretical since it is not required that the residence time of the catalyst and carbon material be the same. Generally speaking, however, the particle size of the second catalyst can vary from about 200 mesh to about 1/2 inch. The first catalyst component is frequently water soluble and can be introduced to the reactor in solution form in which case the particles thereof will generally be quite small. However, if the first component is used in solid form, it will also be conveniently used in a size range of from about 200 mesh to about 1/2 inch.

The reaction time can vary widely. Shorter times favor the production of lower molecular weight hydrocarbons. The reaction time in reactor systems usually incorporates reactor size and feed rate and is referred to as residence time or space velocity and is defined as follows:

$$\text{Residence time (hr.)} = \frac{\text{Volume of reactor}}{\text{Volume feed/time}}$$

$$\text{Space velocity (hr.}^{-1}\text{)} = \frac{1}{\text{Residence time}}$$

The reaction according to the invention is initiated almost instantaneously and long residence times do not eliminate hydrocarbons from the reaction zone. Accordingly, the residence time can be varied as desired. Typical operating values are mentioned in the example which follows.

With reference to FIGURE 1, an operation utilizing a fluidized bed system will be described in detail. Coal pulverized to an average particle size of 35 mesh (Tyler) on a roller mill is preheated to a temperature of about 800° F. and continuously introduced into a fluidized bed reactor such as a simple refractory-lined column including means to introduce a fluidizing gas. Steam is introduced into the coal feed stream 1 and is used to motivate the coal into the reactor. Pulverized catalyst is introduced to the reactor and additional steam is used to motivate the catalyst through feed stream 2. The catalyst contains about 10% by weight sodium carbonate of an average size of 65 mesh and 90% impure iron ore of an average size of about 40 mesh made up of Fe₃O₄, Fe₂O₃, FeO, Fe, and other materials, principally iron carbides. About 40% of the catalyst is in a reduced state which state can be achieved by subjecting spent catalyst to a regenerating step to be described subsequently. Steam is introduced at a rate of about 1.5 moles per mole of carbon to maintain fluidized conditions at space velocities to 400 hr.⁻¹ and the reaction is maintained at a temperature of from 800 to 1000° F. at a pressure of from 100 to 200 p.s.i. Steam can also be introduced directly to the reactor at 3 as shown in FIGURE 1. The catalyst may conveniently be ground with the carbonaceous material and introduced into the reactor through the same feed stream and, of course, the catalyst may be pre-heated.

Solids are separated from the overhead stream 4 by one or more cyclone separators. Other separators can be used and provision can be made to remove solids from a point below the top of the reactor which may be desirable in the event that the carbonaceous material includes a good deal of inert substances. Solids removed from the overhead include catalyst, unreacted coal, ash, and any inerts not otherwise separated from the reactor. The solids may be recycled to the reactor unless they include a substantial amount of inerts in which case these materials are separated in any convenient manner such as by fluidizers and the like. If the iron catalyst is recycled, it may require regeneration in which case the catalyst, together with unreacted coal, is treated with hydrogen or synthesis gas at temperatures of from 500-700° F. or higher.

The gaseous overhead is partially condensed to form a liquid stream 5 and a gaseous overhead stream 6. The gaseous stream includes CO₂, C₁, C₂, LPG and H₂S. This stream can be treated to remove CO₂ and H₂S and pro-

cessed for the LPG and other hydrocarbons present. The stream may be partially recycled to the reactor before or after CO₂ removal to suppress gas formation in the reactor and to provide temperature control.

The liquid product stream 5 contains an aqueous fraction and a hydrocarbon fraction which are mutually insoluble and thus easily divided. The hydrocarbon fraction may be refined by conventional refinery procedures to yield gasoline, diesel fuel and other useful petroleum fractions. The aqueous layer will include oxygenated compounds such as alcohols, aldehydes, ketones, acids and the like which are valuable in themselves and can be recovered by conventional separation techniques such as distillation. The aqueous fraction can be recycled to the reactor as a source of steam. Any oxygenated compounds present in the stream will act to suppress further generation thereof in the reactor.

The process conditions can be varied in one or more ways to favor the production of hydrocarbons over these oxygenated compounds or vice versa. Accordingly, while the instant example illustrates an operation favoring hydrocarbons, the process could be operated at lower temperatures and increased pressure to favor the production of oxygenated compounds.

For the illustrated process, a representative yield based on 100 lbs. of carbon reacted (exclusive of carbon shift) is shown in the following table:

Product	Weight	Percent of product
CO ₂	29.1	19.1
C ₁ and C ₂	32.6	21.3
LPG.....	5.3	3.5
Polymer gasoline.....	23.1	15.2
Straight run gasoline.....	32.3	21.2
Diesel.....	4.6	3.0
Residue.....	2.3	1.5
Oxy's.....	23.3	15.2

Approximately one-third of the total carbon reacted goes to CO₂ via the CO-shift. Overall carbon conversion is around 77%.

Alternative reactor systems can be used. For example, a fixed bed reactor system as shown in FIGURE 2 can be utilized. In this system, the carbonaceous material and catalyst are provided in one or more fixed bed reactors in the form of a column or tank. Two such columns (A) and (B) are shown in FIGURE 2. Steam is introduced to the reactor and the gaseous overhead stream 7 is analogous to stream 5 as shown in FIGURE 1, but may contain some fine entrained solids in which case a separator can be used as shown in FIGURE 1. The catalyst, or a part thereof, may be introduced entrained in the steam. The spent reaction mass is eventually discharged from the reactor and, after regeneration of the catalyst, it may be recycled for further reaction. A plurality of reactors are used to provide a continuous operation. For example, in the two-column system shown in FIGURE 2, valves 8 and 10 are opened to permit steam to enter reactor (A) and to obtain a product stream 7 from the reactor. During that time, valves 9 and 11 are closed, and reactor (B) can conveniently be emptied and re-filled with a fresh charge. The procedure is alternated to provide continuous evolution of product stream 7. While only two reactors are shown, it will be understood that many more could be utilized.

A moving bed reactor, such as that shown in FIGURE 3, can be utilized. In this device, a bed of solid carbonaceous material is moved through the reactor. Steam is introduced to the reactor and may flow counter-current to the moving bed as shown, or may flow concurrent therewith in a fashion analogous to the fluidized reactor of FIGURE 1. In this embodiment, at least part of the catalyst system is preferably mixed and carried with the solids on the moving bed, but some or all of the catalyst may be introduced entrained in the steam.

As mentioned above, the method is also applicable to petroleum fractions. For example, waxy or oily petroleum fractions can be hydrogenated as can lighter fractions. These materials can be introduced as such into the reactor, in which case they would be de-volatilized at reactor conditions to yield a coke-like material and the coke material would undergo a reaction like that described for coal. Coke derived from any source, such as from coal or from processing of these petroleum materials, can also be introduced as such into the reactor and such pre-treatment of the petroleum materials constitutes a convenient way of providing the raw material in a finely divided state.

The invention is also applicable to the in situ processing of deposits of coal, oil shale, oil or tar sands, or other natural formations bearing carbonaceous and hydrogen deficient materials of varying carbon/hydrogen content. This includes formations of "low API gravity" petroleum. The operation is based upon the principles for the direct, single stage reactor conversion process described above. However, instead of the reacting system being confined to a fabricated reactor, the formation bearing the fossil fuel forms the reactor.

Superheated steam is introduced into the formation, with appropriate dissolved or entrained catalysts, and both reacts with and distills the carbonaceous materials and products from the formation. The processes of decomposition and devolatilization occur along with the reaction of the steam and the distillation of the system. The steam also serves to heat the formation and melt the more readily liquefiable portions of the carbonaceous materials. To augment the heating action of the steam, the formation may be heated by partial combustion by cycling with air. Oxygen could also be added with the steam, but this is not recommended due to cost considerations. Still other means of supplying heat (and fracture) would be the use of explosions such as nuclear explosions, or other methods.

The use of an alkali metal carbonate forms a significant feature of the process. The presence of an alkali carbonate catalyst, such as sodium carbonate, permits the steam to react with the carbonaceous material at temperatures as low as of the order of 1000° F. This is particularly important in this in situ-process due to the necessity of heating the formation which may include a substantial amount of inerts.

The catalyst may be introduced with the steam. However, in some formations (such as Green River shale) alkali metal carbonate catalysts such as trona and nahcolite may be present which would reduce the amount of the first catalyst component required to be added. The Fischer-Tropsch catalyst is also added with the steam, but may be added in an amount reduced due to the presence of suitable catalysts naturally present. Green River shale, for example, contains some iron carbonates. As in the reactor operations, the preferred Fischer-Tropsch catalyst is a mixture of metal compounds of different valence states such as mixed ferrous and ferric oxides or carbonates.

The resulting overall product will be hydrocarbon and oxygenated compound mixture plus unreacted carbonaceous materials from the formation. The products exhibit a wide disparity in volatility, from the light hydrocarbons down to high molecular weight compounds. A three-phase product mixture can result: a gas phase, an essentially hydrocarbon liquid phase, and a water-phase—depending on conditions. The gas phase may be considered at its dew point and will carry smaller amounts of the higher molecular weight materials. The hydrocarbon liquid phase, at its bubble point, will contain some dissolved gases, and its extent will depend upon conditions of temperature and pressure.

A condensed water phase may or may not exist depending upon conditions of temperature and pressure. If present, there will be contained dissolved oxygen compounds. The presence of H₂O in the system acts as an azeotrope former to enhance the distillation into the vapor phase

of the less volatile material. It is not necessary for a part of the water to exist as a condensed phase for this action to occur. And in the presence of sufficient H₂O, all identifiable liquids would tend to exist in the vapor phase as an azeotrope.

By adjusting processing rates, and the location of injection and recovery, any liquids present can be removed entrained with the vapor phase. Injection and recovery may be at the same point: for instance, using concentric lines for the steam injection and for product. Or, separate injection and recovery lines can be used. Successful application of the latter requires that an initial contact be made between injection and recovery—by fracture, or otherwise. The operation will of course be enhanced by the insulation of the injection and recovery lines.

The recovered combined product may be refined by the conventional procedures to separation, treating, conversion, etc. The effluent stream would be partially condensed to form a gas phase, hydrocarbon rich liquid, and an aqueous phase. The gas phase is predominately of the light hydrocarbons and carbon dioxide. The aqueous phase contains most of the oxygenated compounds. The gas phase should be treated for CO₂ and H₂S removal, and a part may be recycled with the inlet steam. Recycle would tend to suppress further hydrocarbon gas formation, and provides a stripping action in the formation. The gas recycle could be preheated to reaction conditions. The aqueous phase can be distilled to recover a part of the oxygenated compounds and then recycled to the steam generator. The presence of some oxygenated compounds would tend to suppress oxy formation in favor of other reaction sequences. The spectrum of product distribution is similar to that for above-ground processing in a fabricated reactor.

From the foregoing, it will be seen that the invention provides a single stage conversion of carbonaceous materials to hydrocarbons in good yield. Oxygenated organic compounds can also be produced in good yield. The process involves the use of a two component catalyst system, both components of which can comprise very inexpensive materials and can be easily recycled. Accordingly, the process provides an inexpensive method of producing hydrocarbons, such as gasoline, from carbonaceous raw materials.

What is claimed is:

1. A method of producing hydrocarbons directly from solid or liquid carbonaceous material which comprises: introducing said carbonaceous material and a gas reactant feed stream into a reaction zone, said gas reactant consisting essentially of steam and being introduced in an amount of from 0.25 to 5 moles per mole of carbon contained in the carbonaceous material introduced into the reaction zone; providing in said reaction zone a multi-component catalyst system containing at least one first catalyst component selected from the group consisting of alkali and alkaline earth metal compounds, and at least one second catalyst component selected from the group consisting of group 8 transitional metal compounds; maintaining said reaction zone at a temperature of from 800 to 1200° F. and a pressure of up to 500 p.s.i.; and removing from said reaction zone a product stream containing hydrocarbons produced in said reaction zone.

2. A method according to claim 1 wherein said carbonaceous material is solid and is selected from the group consisting of fossil fuels and coke.

3. A method according to claim 1 wherein said carbonaceous material comprises at least one bituminous material selected from the group consisting of coal, peat, lignite, gilsonite, oil shale, oil sand and tar sand.

4. A method according to claim 1 wherein said carbonaceous material comprises coal.

5. A method according to claim 1 wherein the reaction is carried out at a temperature of from 800 to 1000° F.

6. A method according to claim 1 wherein the reaction is carried out at a pressure of less than 300 p.s.i.

7. A method according to claim 1 wherein the first catalyst component comprises at least one member selected from the group consisting of oxides and carbonates of alkali and alkaline earth metals.

8. A method according to claim 1 wherein the second catalyst component comprises at least one member selected from the group consisting of oxides of iron, nickel and cobalt.

9. A method according to claim 1 wherein said carbonaceous material is a natural deposit of a bituminous material and wherein the reaction is effected by introducing superheated steam at a temperature of at least 1000° F. and said catalyst system simultaneously into said deposit to effect said reaction in situ.

10. A method according to claim 1 wherein said reaction is effected by introducing particles of said carbonaceous material into a reaction zone, providing particles of said first and second catalyst components in said reaction zone, introducing a fluidizing gas comprising said steam to form a fluidized bed of said carbonaceous and catalyst particles in said zone, maintaining the temperature in said zone at from 800 to 1200° F., withdrawing a product stream from said zone comprising hydrocarbon products formed during the reaction, and separating at least one of said hydrocarbon products from said product stream.

11. A method according to claim 1 wherein said carbonaceous material and catalyst are provided in a reaction zone in the form of a fixed bed, said method further comprising withdrawing a product stream comprising hydrocarbon products formed during said reaction from said reaction zone, and separating at least one of said hydrocarbon products from said product stream.

12. A method according to claim 1 wherein the first

component of said catalyst system is present in an amount of from 5 to 75 parts by weight per 100 parts of said system.

13. A method according to claim 1 wherein the catalyst system is present in an amount of from 10 to 200 parts by weight per 100 parts by weight of the total amount of carbon in said carbonaceous material.

14. A method according to claim 1 wherein a bed of said carbonaceous material and catalyst is moved through a reaction zone, and wherein said steam is introduced into the reaction zone, further comprising withdrawing a product stream comprising hydrocarbon products formed during said reaction from said reaction zone, and separating at least one of said hydrocarbon products from said product stream.

15. A method according to claim 8 wherein the first catalyst component is selected from the group consisting of oxides and carbonates of alkali metals.

16. A method according to claim 1 wherein a portion of the product stream is recycled to the reactor.

References Cited

UNITED STATES PATENTS

1,890,434	12/1932	Krauch et al.	208—10
3,252,773	5/1966	Solomon et al.	48—202
2,657,124	10/1953	Gaucher	208—8

DELBERT E. GANTZ, Primary Examiner

V. O'KEEFE, Assistant Examiner

U.S. Cl. X.R.

48—202; 208—8; 260—449