

July 22, 1952

E. W. CLARKE

2,604,432

SOLVENT FRACTIONATION OF WAX-CONTAINING MIXTURES

Original Filed Sept. 16, 1947

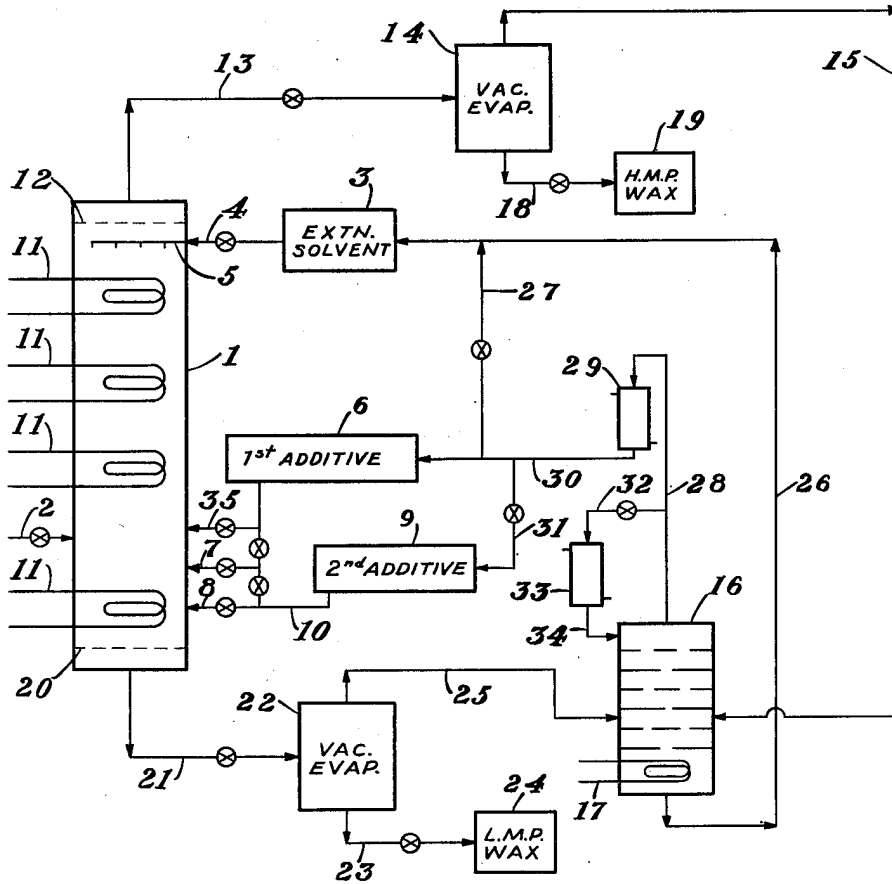

ATTEST

John G. Butz

INVENTOR.

Edgar W. Clarke
BY Robert E. Birch
Attorney

UNITED STATES PATENT OFFICE

2,604,432

SOLVENT FRACTIONATION OF WAX-CONTAINING MIXTURES

Edgar W. Clarke, Laurel Springs, N. J., assignor to The Atlantic Refining Company, Philadelphia, Pa., a corporation of Pennsylvania

Original application September 16, 1947, Serial No. 774,230. Divided and this application November 5, 1949, Serial No. 125,722

3 Claims. (Cl. 196—17)

1

The present invention relates to the treatment of oily waxes, and more particularly to the separation of wax-containing mixtures into fractions of higher and lower melting point, using a solvent comprising nitrobenzene and an additive comprising BB' dichlorodiethyl ether.

This application is a division of copending application, Serial Number 774,230, filed September 16, 1947, now Patent Number 2,578,510, and entitled "Solvent Fractionation of Wax-Containing Mixtures."

The present invention is especially applicable to the de-oiling of hydrocarbon waxes containing not more than about 70% of oil, and to the separation of wax mixtures of low oil content into fractions of different melting point. The process of the present invention may be applied in the refining, purification, or separation of wax stocks such as petroleum slack wax, crude microcrystalline wax, paraffin waxes, petrolatum wax, montan wax, ceresin, ozokerite, waxes from the destructive or non-destructive hydrogenation of mineral oil, synthetic hydrocarbon oil, shale oil, coal, and waxes produced synthetically by the catalytic reaction of hydrocarbons, or waxes derived from the modified Fischer-Tropsch reaction of carbon monoxide and hydrogen. The process of this invention is especially applicable in the separation of wax mixtures containing color bodies and oil into a higher melting wax fraction of light color and low oil content, and a lower melting wax fraction of darker color and containing most of the oil originally present in the wax mixture.

In accordance with this invention, a wax-containing mixture is separated into fractions of higher and lower melting point by countercurrently contacting the wax-containing mixture in an extraction zone with an extraction solvent and a solvent additive or additives at a temperature such that two liquid phases are formed, one comprising the higher melting wax fraction with minor amounts of solvent and additive, and the other comprising the lower melting wax fraction with major amounts of solvent and additive, separating the liquid phases from one another, and removing the solvent and additive from each. The extraction solvent and additives employed may have a density greater than that of the wax. However, when the additive or additives are partially immiscible with the extraction solvent and are less dense than such solvent or the wax, the additive or additives will flow countercurrent to the extraction solvent and will appear with that liquid phase comprising the higher melting wax fraction. The success of the process depends upon the control of the temperature throughout the extraction zone and upon the regulation of

2

the proportions of solvent and additive used, and the points of introduction of the wax-containing mixture, the solvent, and the additive into the extraction zone.

The extraction solvent may be defined as an agent which, when intimately mixed with a wax-containing mixture, forms two liquid phases or layers, one comprising a raffinate phase containing mostly wax of higher melting point than the untreated wax and a portion of the solvent, and the other comprising an extract phase containing mostly solvent, and wax of lower melting point than the untreated wax, as well as a major portion of the color bodies and oil originally present in the untreated wax.

The solvent additive may be defined as an agent used in conjunction with the extraction solvent for the purpose of modifying the characteristics of the extraction solvent. The additive may lower the temperature at which solid wax precipitates out of the extraction solvent, or it may raise the miscibility temperature of the extraction solvent with the wax. However, the additive chosen for a particular extraction solvent must not excessively lower the selectivity of the extraction solvent at the temperature of extraction.

The extraction solvent may be employed in amounts ranging from 1 to 5 volumes of solvent per volume of untreated wax stock, while the additive or additives may be used in amounts ranging from 0.05 to 1 volume per volume of untreated wax.

The extraction solvents which may be employed in accordance with the present invention comprise nitrobenzene containing a small amount of BB' dichlorodiethyl ether.

The solvent additive or additives, which are usually employed in amounts constituting not more than 50% by volume of the extraction solvent, comprise BB' dichlorodiethyl ether.

The process of the present invention may be carried out in a multi-stage batch countercurrent extraction system or in a continuous countercurrent extraction system, preferably a tower provided with perforated baffles or containing a packing material such as ceramic shapes, tiles, metal wool, or fragments of ceramic material, glass, pumice, carborundum, or concrete. For most effective operation, a temperature gradient is maintained in the system by means of heating or cooling coils or jackets, the temperature increasing in the direction of flow of the raffinate or higher melting wax fraction.

The present invention may be further understood with reference to the accompanying drawing which illustrates diagrammatically a contin-

3

uous extraction system suitable for carrying out the process.

Referring to the drawing, a wax-containing mixture is continuously introduced, in liquid condition, into the extraction tower 1 through valve controlled pipe 2 at a rate of 100 volumes per hour. An extraction solvent comprising nitrobenzene containing a small amount of BB' dichlorodiethyl ether is continuously introduced from vessel 3 by means of valve-controlled pipe 4 and manifold 5 into the upper section of the tower below the raffinate outlet at a rate of 200 volumes per hour. The first additive comprising BB' dichlorodiethyl ether is continuously introduced from vessel 6 through valve-controlled pipe 7 into the extraction tower 1 below the wax inlet at a rate of 10 volumes per hour. The second additive also comprising BB' dichlorodiethyl ether is continuously introduced by valve-controlled pipe 8 into the extraction tower 1 between the point of introduction of the first additive and the outlet of the extract phase, at a rate of 10 volumes per hour, such second additive being delivered from vessel 9 through pipe 10. An intimate countercurrent contacting of the wax stock, the extraction solvent, and the additives is effected in tower 1, a temperature gradient being maintained in the tower by means of coils 11 through which a heating or cooling medium is circulated as required, the temperature adjacent the top of the tower being higher than that adjacent the bottom of the tower, the contents of the tower being entirely in the liquid phase. The wax stock, being subjected to the action of the solvent and additives, is caused to separate by solvent action into two fractions, the higher melting fraction wax passing upwardly through the tower together with a minor amount of dissolved extraction solvent and additive, and being withdrawn therefrom above the level of the dotted line 12 representing the higher melting wax phase relatively free of entrained, immiscible solvent and additive. The raffinate phase comprising the higher melting wax and dissolved solvent and additive is passed from the top of tower 1 through valve-controlled pipe 13 into a vacuum evaporator or still 14 wherein the solvent and additive is removed from the higher melting wax by vaporization, the solvent and additive vapors passing through pipe 15 into fractionating tower 16 provided with a reboiler or heating coil 17, while the higher melting wax is drawn from the bottom of evaporator 14 and delivered by valve-controlled pipe 18 into storage vessel 19. Such wax fraction was white in color, and had a substantially higher melting point and a lower oil content than the original waxy mixture.

The extract phase comprising the lower melting wax fraction, color bodies, oil, and the major portion of the extraction solvent and additives is withdrawn from the lower section of tower 1 beneath the level of the dotted line 20 representing the extract phase relatively free of entrained, higher melting wax. The extract phase is delivered by valve-controlled pipe 21 into a vacuum evaporator or still 22 wherein the solvent and additives are vaporized from the lower melting wax, the latter being drawn from the bottom of the evaporator and passed by valve-controlled pipe 23 to storage vessel 24. The lower melting wax was brown in color and had a substantially lower melting point and a higher oil content than the original waxy mixture.

4

The solvent and additive vapors are passed from the top of evaporator 22 through pipe 25 into fractionating tower 16, wherein such vapors together with those introduced through pipe 15, are fractionated, the extraction solvent, i. e., nitrobenzene, being drawn from the bottom of the tower as a liquid and returned by means of pipe 26 to the solvent storage vessel 3 for reuse. The desired small amount, for example, 5% to 10% of BB' dichlorodiethyl ether is incorporated in the nitrobenzene by introducing the BB' dichlorodiethyl ether from vessel 6 by means of valve-controlled pipe 27. The additive, i. e., BB' dichlorodiethyl ether, separated from the nitrobenzene by fractionation in tower 16 is taken overhead as vapor by pipe 28, condensed in condenser 29 and returned by pipes 30 and 31 to vessels 6 and 9, respectively. A portion of the vapor stream may be diverted through valve-controlled pipe 32, condensed in condenser 33, and the condensate returned as reflux to the top of tower 16 by pipe 34.

Depending upon the temperature of operation, the first additive may be introduced somewhat above the point of introduction of the liquefied waxy stock, for example, by means of valve-controlled pipe 35 rather than through valve-controlled pipe 7, in which case the second additive may be admitted through either or both of valve-controlled pipes 7 and 8 below the point of introduction of the wax stock. In general, the raffinate wax phase withdrawn from the extraction tower will contain from 5% to 25% of solvent and additive, while the extract wax phase will contain from 55% to 90% of solvent and additive.

In the event that the extraction is to be carried out in a multi-stage batch countercurrent system, for example, a 4-stage system using the solvent and additives specifically set forth above, the wax stock would be introduced into the first stage extractor, the extraction solvent comprising nitrobenzene and a small amount of BB' dichlorodiethyl ether would be introduced into the fourth stage extractor, and the first additive, i. e., BB' dichlorodiethyl ether, would be introduced into the first stage extractor. The second additive, e. g., the same ether, would be introduced into the second stage extractor. The extract phase is withdrawn from the first stage extractor, while the raffinate phase would be removed from the fourth stage extractor. The temperature would increase progressively from the first stage to the fourth stage, using the waxy stock, solvent, and additives described hereinabove. It is to be understood, of course, that the quantities and composition of the solvent and of the additives may be varied within certain limits.

Exemplary of the solvent and additive materials which may be used in accordance with this invention is the following, the quantities being volumes per unit volume of waxy stock:

Extraction Solvent	1st Additive	2nd Additive
Nitrobenzene +10% BB' dichlorodiethyl ether 2±0.4 vols.	BB' dichlorodiethyl ether 0.1 ±0.05 vols.	BB' dichlorodiethyl ether 0.1±0.05 vols.

The present invention is further illustrated by the following example, which, however, is not to be construed as limiting the scope thereof:

(1) A slack wax having a melting point of 113° F. and an oil content of 24.2% by weight

5

was extracted in a system similar to that shown in the accompanying drawing, the extraction solvent comprising 2 volumes of nitrobenzene containing 10% of BB' dichlorodiethyl ether, the first additive comprising 0.1 volume of BB' dichlorodiethyl ether, and the second additive comprising 0.1 volume of BB' dichlorodiethyl ether. The slack wax was introduced into tower 1 by pipe 2, the solvent by pipe 4 and manifold 5, the first additive by pipe 7 and the second additive by pipe 8. The temperature in the extraction tower was maintained constant at 95° F. After countercurrent contacting and removal of the raffinate phase from the top of the tower, and the extract phase from the bottom of the tower, the solvent and additives were recovered from the wax fractions by vacuum evaporation and fractionation. The results are shown in the following table:

	Charge Wax	Raffinate Wax	Extract Wax
Weight Percent Yield percent.....	100	51.8	48.2
Melting Point °F.....	113.1	132.3	98.5
Oil Content, Weight Percent.....	24.2	0.1	50.2
Refractive Index at 176°F.....	1.43625	1.42950	1.44155
A. P. I. Gravity.....	40.5	42.3	37.4
Color.....	Brown	White	Dark Brown
Firmness.....	Nil	Good	Nil
Tackiness.....	Poor	Moderate	Poor
Plasticity.....	Too Soft	Good	Too Soft
Fiber Length.....	Short	Long	Short
Flexibility.....	Poor	Moderate	Poor

Where the extraction operation is conducted in a tower, it has been found that a tower having a height of about 40 feet and a diameter of 6 feet is satisfactory. The tower is provided with suitable packing to within about 4 feet of the top and bottom thereof, such spaces functioning as quiescent zones in which entrained materials are permitted to separate from the raffinate and extract phases, respectively. In such a tower, the wax stock is charged at a point about 13 feet from the bottom thereof, or approximately 1/3 the distance from the bottom of the tower. The extraction solvent is charged just above the upper level of the packing, for example, 3 to 4 feet from the top of the tower. The first additive may be introduced adjacent the point of introduction of the wax stock, for example, 2 feet above or below the wax inlet. The second additive is introduced approximately 2 feet below the point of introduction of the first additive. These values may be altered somewhat, depending upon the tower design, the solvent and additives used, and the temperatures maintained at various levels in the tower. The raffinate phase is withdrawn from the top of the tower, and the extract phase from the bottom thereof, the extraction solvent being more dense than the wax stock.

I claim:

1. The method of separating a wax-containing mixture into fractions of higher and lower melting point, which comprises countercurrently contacting said wax-containing mixture in an extraction zone with an extraction solvent and solvent additives at a temperature such that two immiscible liquid phases are formed, one comprising the higher melting wax fraction containing solvent and additives, and the other comprising solvent and additives and the lower melting wax fraction, separating the phases from one another, and removing the solvent and additives from

6

each, the solvent being introduced into the extraction zone near the point of withdrawal of the higher melting wax fraction, the first additive being introduced adjacent the point of introduction of the wax-containing mixture, and the second additive being introduced between the point of introduction of the first additive and the point of withdrawal of the lower melting wax fraction, the solvent comprising 1.6 to 2.4 volumes of nitrobenzene containing a small amount of BB' dichlorodiethyl ether per volume of wax-containing mixture, the first additive comprising 0.05 to 0.15 volumes of BB' dichlorodiethyl ether per volume of wax-containing mixture, and the second additive comprising 0.05 to 0.15 volumes of BB' dichlorodiethyl ether per volume of wax-containing mixture.

2. The method of separating a wax-containing mixture into fractions of higher and lower melting point, which comprises countercurrently contacting said wax-containing mixture in an extraction zone with an extraction solvent and solvent additives at a temperature such that two immiscible liquid phases are formed, one comprising the higher melting wax fraction with minor amounts of solvent and additives, and the other comprising the lower melting wax fraction with major amounts of solvent and additives, separating the phases from one another, and removing the solvent and additives from each, the solvent being introduced into the extraction zone near the point of withdrawal of the higher melting wax fraction, the first additive being introduced between the point of introduction of the wax-containing mixture and the point of withdrawal of the lower melting wax fraction, and the second additive being introduced between the point of introduction of the first additive and the point of withdrawal of the lower melting wax fraction, the solvent comprising 1.6 to 2.4 volumes of nitrobenzene containing 10% of BB' dichlorodiethyl ether per volume of wax-containing mixture, the first additive comprising 0.05 to 0.15 volumes of BB' dichlorodiethyl ether per volume of wax-containing mixture, and the second additive comprising 0.05 to 0.15 volumes of BB' dichlorodiethyl ether per volume of wax-containing mixture.

3. In a method of separating a wax-containing mixture into fractions of higher and lower melting point, wherein the wax-containing mixture is contacted in an extraction zone with an extraction solvent and solvent additives at a temperature above the melting point but below the temperature of complete miscibility of the mixture, the steps which comprise introducing 1 volume of liquefied wax-containing mixture into the extraction zone at a point intermediate the points of withdrawal of the higher and lower melting waxes including the solvent and additive, introducing 1.6 to 2.4 volumes of extraction solvent comprising nitrobenzene containing 10% of BB' dichlorodiethyl ether at a point adjacent the point of withdrawal of the higher melting wax fraction including solvent and additive, but intermediate said point of withdrawal and the point of introduction of the liquefied wax-containing mixture, and introducing 0.05 to 0.15 volumes of an additive comprising BB' dichlorodiethyl ether intermediate the point of introduction of the liquefied wax-containing mixture and the point of withdrawal of the lower melting wax fraction including solvent and additive, introducing 0.05 to 0.15 volumes of an additive comprising BB' dichlorodiethyl ether at a point intermediate the point of

7

introduction of the first additive and the point of withdrawal of the lower melting wax fraction including solvent and additive, effecting counter-current contact between the liquefied wax-containing mixture and the solvent and additives at a temperature such that two immiscible liquid phases are formed, one phase comprising the higher melting wax fraction containing minor amounts of solvent and additives, and the other liquid phase comprising the lower melting wax fraction and major amounts of solvent and additives, the temperature in the extraction zone increasing in the direction of flow of the higher melting wax fraction, separately withdrawing the respective liquid phases from the extraction zone,

5

10

15

8

and removing the solvent and additives from each.

EDGAR W. CLARKE.

REFERENCES CITED

The following references are of record in the file of this patent:

UNITED STATES PATENTS

Number	Name	Date
2,017,432	Bahlke	Oct. 15, 1935
2,063,369	Diggs et al.	Dec. 8, 1936
2,138,833	Brown et al.	Dec. 6, 1938
2,160,930	Whiteley et al.	June 6, 1939