

154002274

(214)

IV. MISCELLANEOUS INFORMATION

154002275

(215)

IV. MISCELLANEOUS INFORMATION

<u>Ruhrchemie</u>	<u>Page No.</u>
Catalyst Requirements	216
Catalyst Costs	217
Capital Costs Synthesis Plant	219-A
Utility Requirements Synthesis Plant	222
Labor Requirements Synthesis Plant	223

TABLE VI

CATALYST REQUIREMENTS FOR SYNTHESIS PLANT TO PRODUCE 4800 BARRELS PER DAY

	<u>Seven Atmospheres</u>	<u>One Atmosphere</u>
Oil Yield	140 g./m ³	120 g./m ³
Ideal Gas Required	5,860,000 cu.ft. (166,000 m ³)/hr.	6,780,000 cu.ft. (192,000 m ³)/hr.
Synthesis Gas Required	6,900,000 cu.ft. (195,000 m ³)/hr.	7,950,000 cu.ft. (225,000 m ³)/hr.
Synthesis Gas per Chamber	26,800 cu.ft. (760 m ³)/hr./chamber	25,600 cu.ft. (725 m ³)/hr./chamber
Number Chambers	257 + 15 = 272	310 + 22 = 332
Catalyst Life	6 months	4 months
Chamber Fillings	514/yr.	930/yr.
Chamber Fillings	1.5/day	2.7 day
Cobalt in Chambers	480,000 lb. (218 tons)	576,000 lb. (262 tons)
Cobalt in Transportation, etc. (3%)	15,400 lb. (7 ton)	18,600 lb. (8 tons)
Cobalt in Catalyst Plant	57,000 lb. (26 tons)	68,000 lb. (31 tons)
Cobalt - Total Required	552,000 lb. (251 tons)	662,000 lb. (301 tons)
Cobalt - Time in Catalyst Plant	20 days	14 days
<u>Utilities</u>		
Condensate Water	130-160 lb./lb. cobalt	130-160 lb./lb. cobalt
Cooling Water	440,000 lb. (200 tons)/hr.	715,000 lb. (325 tons)/hr.
Steam	9,000-15,000 lb. (4-7 tons)/hr.	15,000-24,000 lb. (7-11 tons)/hr.
Electricity Installed	780 kilowatts/hr.	1400 kilowatts/hr.
Consumption	200 kilowatts/hr.	325 kilowatts/hr.
Building and Equipment	2,100,000 R.M.	3,500,000 R.M.

Table VI opposite contains the estimated catalyst plant requirements for a synthesis installation to produce 4800 barrels of oil per day (200,000 tons of oil per year). The oil yield and the catalyst life were affected by the pressure under which the synthesis reaction was carried out, and consequently the estimates have been given upon the bases:

Catalyst
Plant
Requirements
Table VI

1. Atmospheric pressure operation.
2. Seven atmospheres pressure operation.

This table shows 272 reaction chambers would be required for the seven atmospheres plant while 332 chambers would be required for the atmospheric pressure plant. The total cobalt requirements would be, respectively, 552,000 pounds (251 tons) and 662,000 pounds (301 tons), and the quantities of catalyst that would have to be manufactured daily would be 9000 pounds (4 tons) and 17,000 pounds (7.5 tons) respectively.

The item included at the bottom of the tabulation as "Building and Equipment" was based on a completely housed plant. It was estimated that the figures shown in the table could be decreased by as much as one-third when the climatic conditions would permit exposure of a large part of the equipment.

154002278

(217)

The following tabulations give the cost of catalyst manufacture following the Ruhrchemie methods but using American raw materials for the catalyst. The item about which least was known was the labor requirements.

Catalyst
Costs

COST OF ORIGINAL CATALYST (UNITED STATES CONDITIONS)

151002272

Basis: 1,000 Kg. Cobalt

<u>Materials</u>	<u>Kg. Pure Material per 1,000 Kg. Cobalt</u>	<u>= Pounds</u>	<u>% Purity of Commercial Material</u>	<u># of Commer. Material Required</u>	<u>Cost in \$ / #</u>	<u>Total Cost of Material</u>
Cobalt	1,000	2,200	100	2,200	123.00	\$2,700.00
Thoria	25	55	100	55	325.00	180.00
Magnesia	300	660	100	660	13.00	86.00
Kieselguhr	2,000	4,400	100	4,400	2.50	110.00
Sodium Carbonate	3,000	6,600	58	11,400	1.23	140.00
Nitric Acid	1,600	3,500	54	6,500	5.00	325.00
Sodium Fluoride	120	265	100	265	7.50	20.00
						<u>\$3,561.00</u>

Cost/# Red. Cat. (Materials Only) = $\frac{\$3,561.00}{7,000}$ = \$0.51/#

Cost of Catalyst

Basis: 1,000 Kg. Co = 7,000# reduced catalyst.

Debit:

Cost of Raw Materials and Chemicals	\$3,561.00
Cost of Labor at 75¢ man hr.	150.00
Condensate Water (Washing) at 20¢ ton	26.00
Cooling Water at 1/4 ¢ ton	8.50
Power at 1/2 ¢ KWH	<u>17.00</u>
Total Debit	\$3,762.50

Cost of Catalyst (excl. F.C.) = $\frac{\$3762.50}{7000} = \0.54 per lb.

Cost of Reworking:

Basis: 1,000 Kg. Cobalt

Debit:

Cost of Chemicals (Incl. Make-Up Cobalt)	\$ 888.00
Cost of Labor at 75¢ man hr.	150.00
Condensate Water (Washing) at 20¢ ton	26.00
Cooling Water at 1/4 ¢ ton	8.50
Power at 1/2 ¢ KWH	<u>17.00</u>
Total Debit	\$1,089.50

Cost of Reworking Cat. = $\frac{\$1089.50}{7000} = \0.155 per lb.

The following tabulations were made up from data given by Ruhrchemie. It will be noted that the capital costs for the synthesis plant were not given upon the same basis as the data upon catalyst requirements and utilities. In view of the numerous interpretations that might be given the various items, no further conversions were attempted. It would be helpful to have official figures for a complete plant, all items being upon a single basis, preferably upon a given oil production.

Capital
Costs

CAPITAL COSTS FOR SYNTHESIS PLANT

(Basis: Capacity of 40,000 M³/Hr.)
= 34,000,000 Cu.Ft./Day

<u>Low Pressure Plant:</u>	<u>R.M.</u>	<u>Dollars</u> <u>IRM=\$.40</u>
H ₂ S Removal	500,000	\$200,000.
Organic Sulfur Removal	350,000	140,000.
Low Pressure Ovens (59)	3,840,000	1,540,000.
Low Pressure Condensation	250,000	100,000.
Low Pressure Charcoal Absorp.	800,000	320,000.
Low Pressure Compressors	70,000	28,000.
Low Pressure Blowers	87,000	34,700.
	<u>5,897,000</u>	<u>\$2,362,700.</u>

<u>High Pressure Plant:</u>	<u>R.M.</u>	<u>Dollars</u> <u>IRM=\$.40</u>
H ₂ S Removal	500,000	\$200,000.
Organic Sulfur Removal	350,000	140,000.
High Pressure Ovens (56)	4,030,000	1,610,000.
High Pressure Condensation	250,000	100,000.
High Pressure Oil Absorp.	600,000	240,000.
High Pressure Compressors	880,000	350,000.
	<u>6,610,000</u>	<u>\$2,640,000.</u>

Operating Costs

	<u>R.M.</u>	<u>Dollars</u> <u>IRM=\$.40</u>
Maintenance (1-1/2% Per Year)	-	-
Miscellaneous Supplies (Per Year)	100,000	\$ 40,000.

CAPITAL COSTS FOR SYNTHESIS PLANT
TO PRODUCE 4800 BARRELS OIL PER
DAY
(assumed)

<u>Low Pressure Plant:</u>	<u>R.M.</u>	<u>Dollars</u> <u>IRM=\$.40</u>
H ₂ S Removal	2,810,000	\$1,112,000.
Organic Sulfur Removal	1,970,000	790,000.
Low Pressure Chambers (332)	21,600,000	8,640,000.
Condensation	1,410,000	560,000.
Charcoal Absorption	4,500,000	1,800,000.
Compressors	390,000	156,000.
Blowers	490,000	196,000.
	<u>33,170,000</u>	<u>\$13,254,000.</u>

<u>High Pressure Plant:</u>	<u>R.M.</u>	<u>Dollars</u> <u>IRM=\$.40</u>
H ₂ S Removal	2,440,000	\$ 976,000.
Organic Sulfur Removal	1,710,000	684,000.
High Pressure Chambers (272)	19,600,000	7,840,000.
Condensation	1,220,000	488,000.
Oil Absorption	2,930,000	1,170,000.
Compressors	4,290,000	1,715,000.
	<u>32,190,000</u>	<u>\$12,873,000.</u>

UTILITY REQUIREMENTS
FOR
SYNTHESIS PLANT

Basis: 92 Tons Liquid Product Per Day =
820 Bbl.(42)/Day

Fuel Requirements (Gas with HHV = 320 BTU/Cu.Ft.)
Organic Sulfur Removal
Absorption System (Press. Operation)

Cu.Ft./Day
1,010,000
190,000

Steam Requirements (280#/Sq.In.)
Heat Ovens and Regeneration (52 Ovens)

#/Hr.
114

Steam Requirements (15#/Sq.In.)
To Strip Out Gasol.
To Strip Out Light Benzin
Total for Charcoal Stripping

#/Hr.
3,500
19,400
22,900

Power Requirements
Organic Sulfur Removal (Blower)
Synthesis (Water Pumps, H₂ Compressor, etc.)
Condensation (Water Circu. etc.)
Charcoal Absorption Plant
Compression of Gasol.
Compression of Synthesis Gas:
To 3 Meters of H₂O
To 10 Atm.

K.W.
32
39
114
114
52
525
4,500

Water Requirements
Cooling Water
Boiler Feed Water

GPM
700
130

154002285

Labor Requirements

Blowers	1 man per shift
Purification	2 men per shift
Supervisors (synthesis plant)	6 men per shift
Small repairs, etc.	5 men per shift
Filling and cleaning oven	10 men per day
Condensation	1 man per shift
Activated charcoal	2 men per shift
Repairs (entire plant)	15-20 men per shift
Laboratory supervision	11 men per shift
Laboratory helpers	6 men per shift

154002286

(224)

APPENDIX

CONVERSION UNITS

0.394 X Centimeters	=	Inches
0.155 X Square Centimeters	=	Square Inches
0.061 X Cubic Centimeters	=	Cubic Inches
3.28 X Meters	=	Feet
10.76 X Square Meters	=	Square Feet
35.30 X Cubic Meters	=	Cubic Feet
14.70 X Atmospheres	=	Pounds Per Square Inch
14.20 X Kg./Sq. Cm.	=	Pounds Per Square Inch
1.42 X Meters Water	=	Pounds Per Square Inch
2200 X Metric Tons	=	Pounds
372 X Metric Tons Oil	=	Gallons Oil
8.86 X Metric Tons Oil	=	Barrels Oil
0.00397 X Calories	=	B.T.U.

154002288

FIGURE XXII

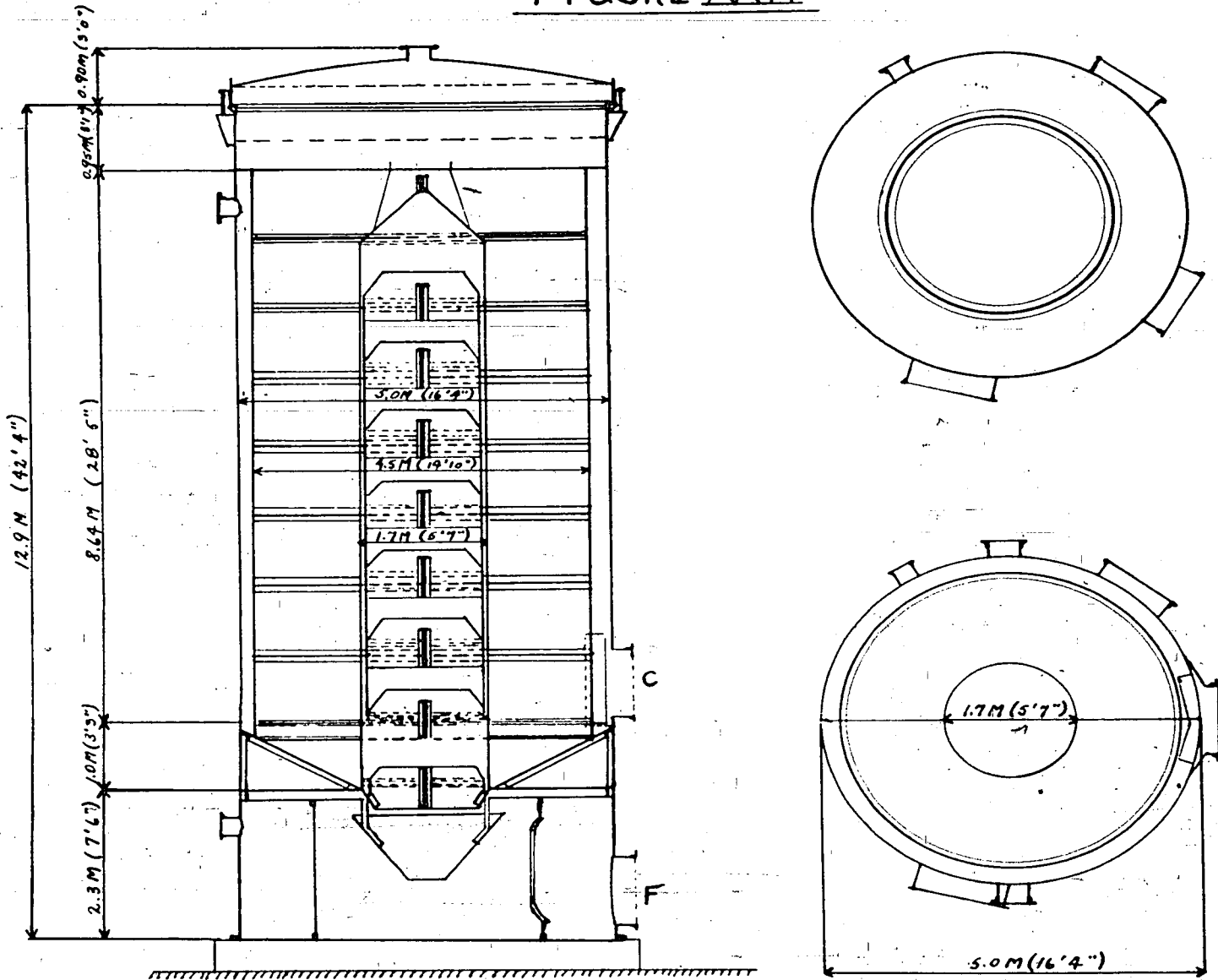

ORGANIC SULFUR REMOVAL
SCREEN TOWER

ORGANIC SULFUR REMOVAL

SCREEN TOWER

The organic sulfur removal screen tower consisted of two perforated sheet cylinders which were placed one inside of the other. The fine purifying mass lay in the annular space between the two perforated sheet cylinders. The inner perforated sheet cylinder was divided into several sections, which could be removed from above. This construction made it possible to discharge the tower downwards through the inner perforated sheet cylinder. The crude gas flowed through the connecting piece "C" into the outer annular space of the tower and from there it was uniformly distributed through the contact mass into the central tube in order to come out through the connecting piece "F" as purified gas.

Figure XXII

228913

FIGURE XXIII

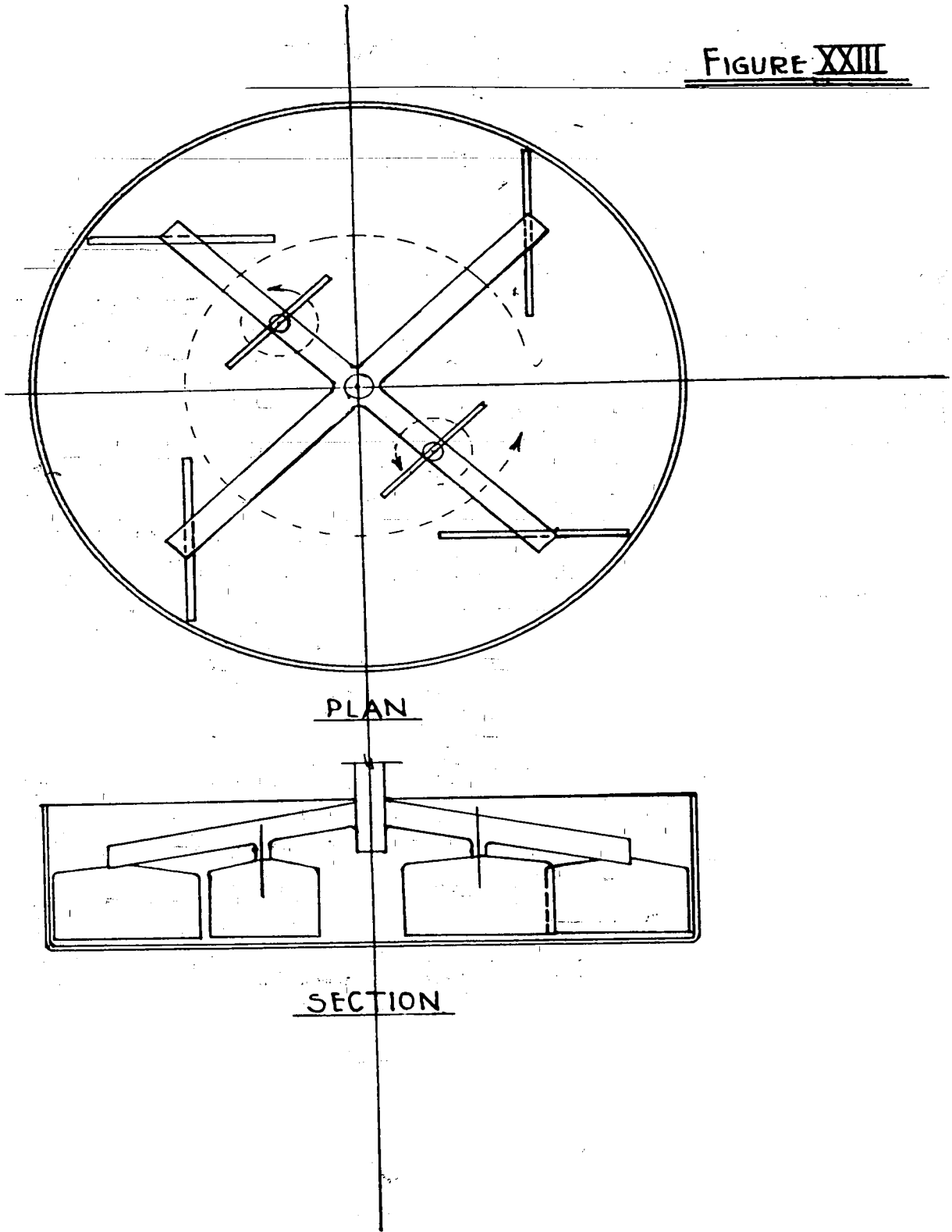

ORGANIC SULPHUR CATALYST MIXER

ORGANIC SULFUR CATALYST MIXER

The solid Luxmasse and solid sodium carbonate were placed in the mixer and, after vigorous stirring for a few minutes, became a semi-fluid paste. The fine material from the screening operation was then added and the mixing continued for a short period. The mixer was not provided with heating coils although the pasty mass would quickly solidify at temperatures below about 85°F. (32°C.).

Figure XXIII

154002291

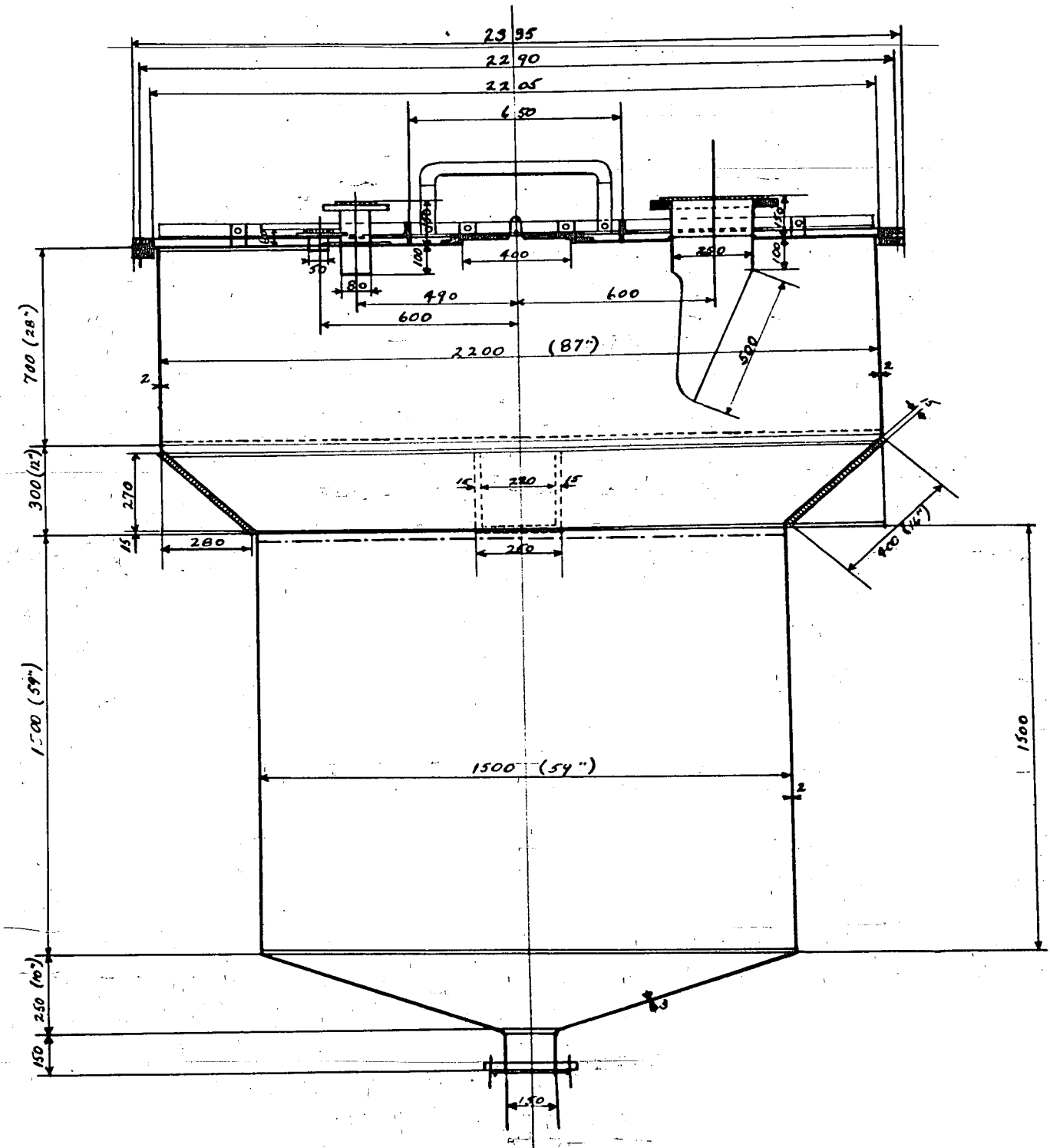
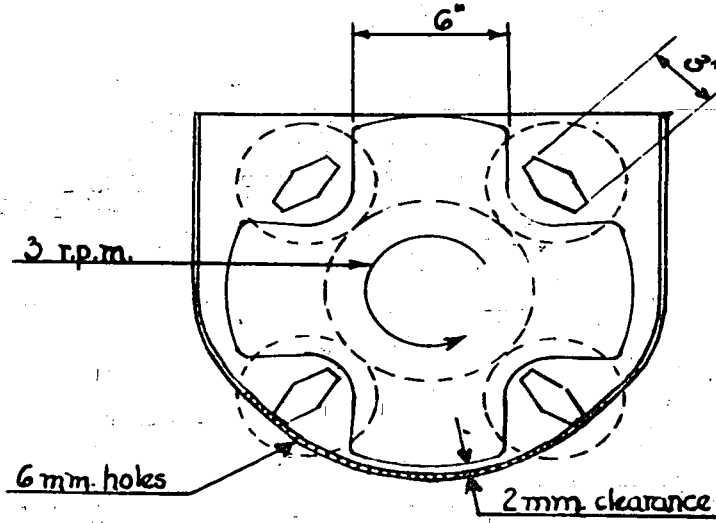

FIGURE XXIV
PRECIPITATION VESSEL

THE PRECIPITATION VESSEL

The precipitation vessel was 9 feet (2.75 meters) high and had an inside diameter of 7 feet, 3 inches (2.2 meters) at the top of the vessel. The total free volume was about 245 cubic feet (7 cubic meters). A high speed stirrer (930 R.P.M.) was fitted in the center of the tank and was used during the precipitation step. All metal which was in contact with the catalyst was of 18-8 chrome-nickel steel. The precipitation vessel was also equipped for indirect (steam coils) and direct heating.

Figure XXIV



CROSS SECTION

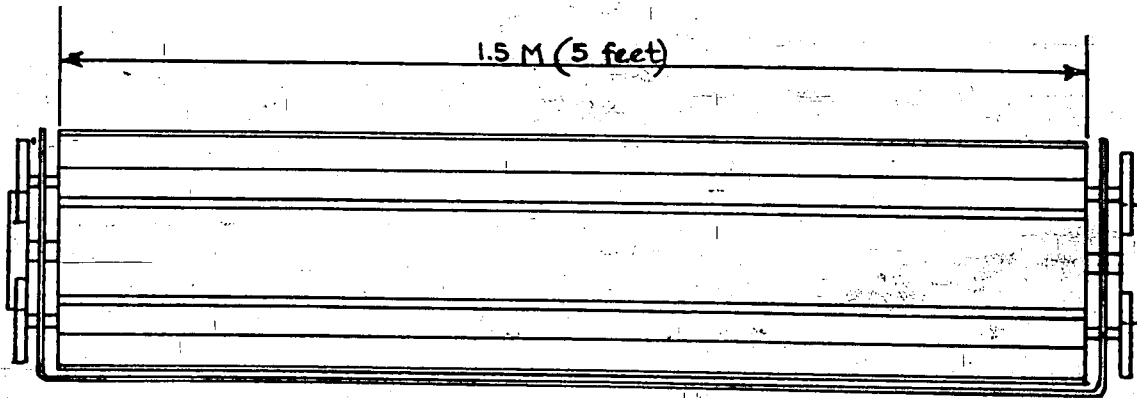

LONGITUDINAL SECTION

EXTRUDER

THE EXTRUDER

The purpose of the extruder was to deliver the catalyst in shaped pieces to the drier, and consequently it was located immediately above the Büttner drier. It consisted of a U-shaped steel plate, about five feet long, with six millimeter holes drilled into the bottom of the U. The holes were so distributed that there were more holes on the end of the U-shaped plate than on the other that was nearest the periphery of the drier, the purpose of this arrangement being radial distribution of the extruded material on the trays of the Büttner drier. Revolving inside the U-shaped plate was a large cylindrical scraper about 16 inches outside diameter, in the shape of a cross, which rotated at 3 R.P.M. There were also four smaller scrapers revolving inside the dished-in parts of the larger scraper. The gears were so arranged that the smaller scrapers also revolved at 3 R.P.M.

Catalyst, plus about 70% water, was introduced into the extruder and pressed by the scrapers through the six millimeter holes onto the trays of the Büttner drier. It was important that the catalyst be at a temperature of about 85°F. while being extruded.

Figure XXV

154002295

FIGURE XXVI

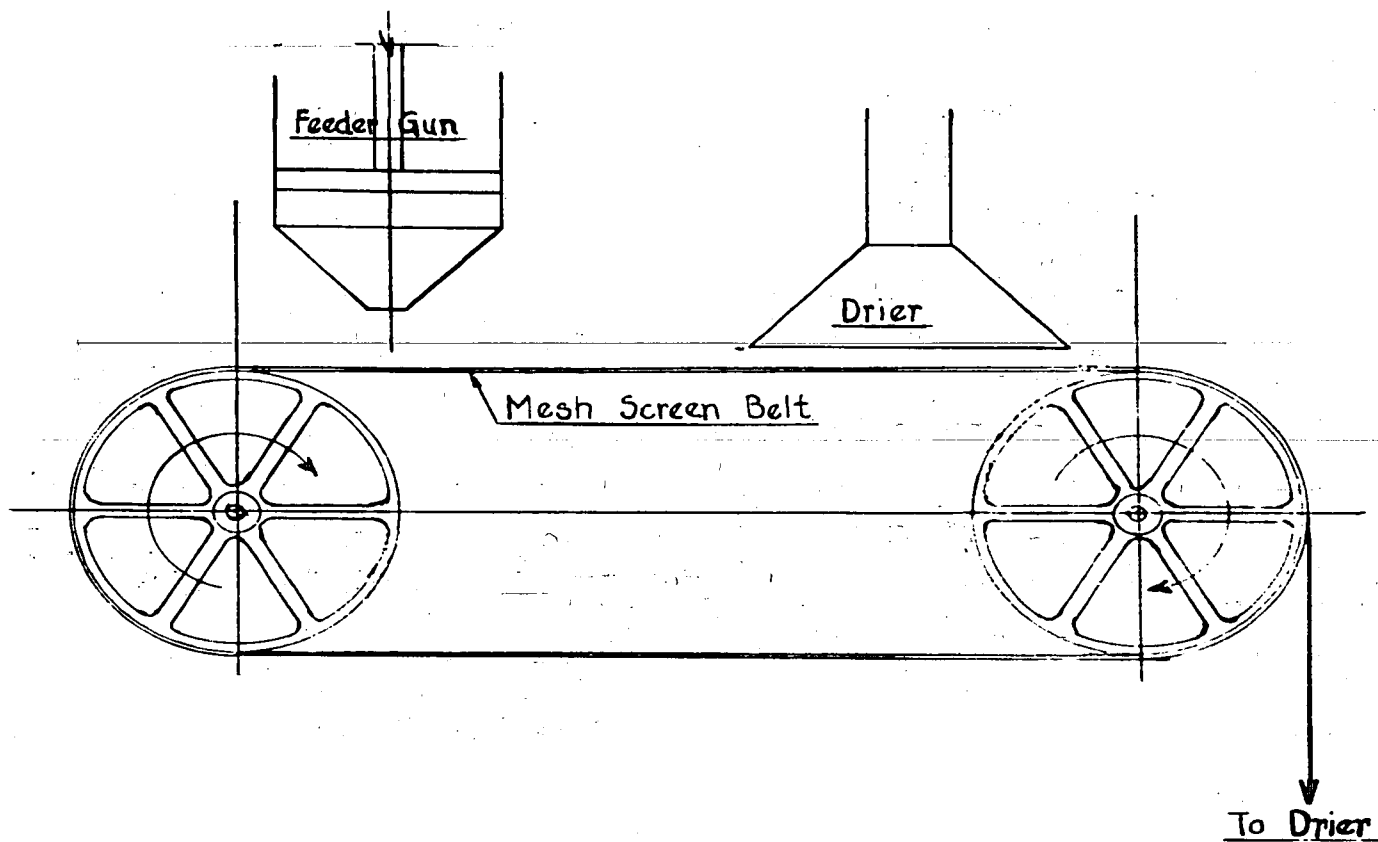

CATALYST FORMING APPARATUS

CATALYST FORMING APPARATUS

It had been found that the catalyst could also be formed into rods by a piston-type extruder. The catalyst was placed in a feeder gun and pressed through a hole from which it fell onto a conveyor belt, covered with a fine mesh (two millimeter) screen. The catalyst was partially dried on the belt--from 65% water to 60% water. In falling on the screen the catalyst rods were nicked, and after the preliminary drying the rods broke at the nicked points and fell onto the trays of a Büttner drier.

Figure XXVI

154002297

FIGURE XXVII

Stagger plates on Alternate trays

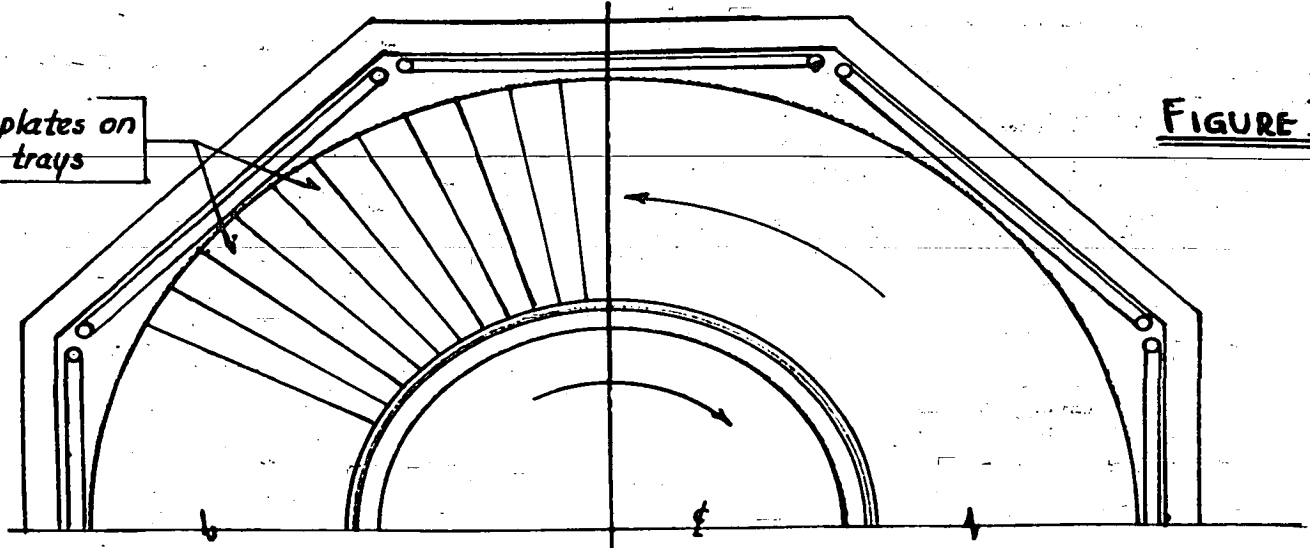

PLAN

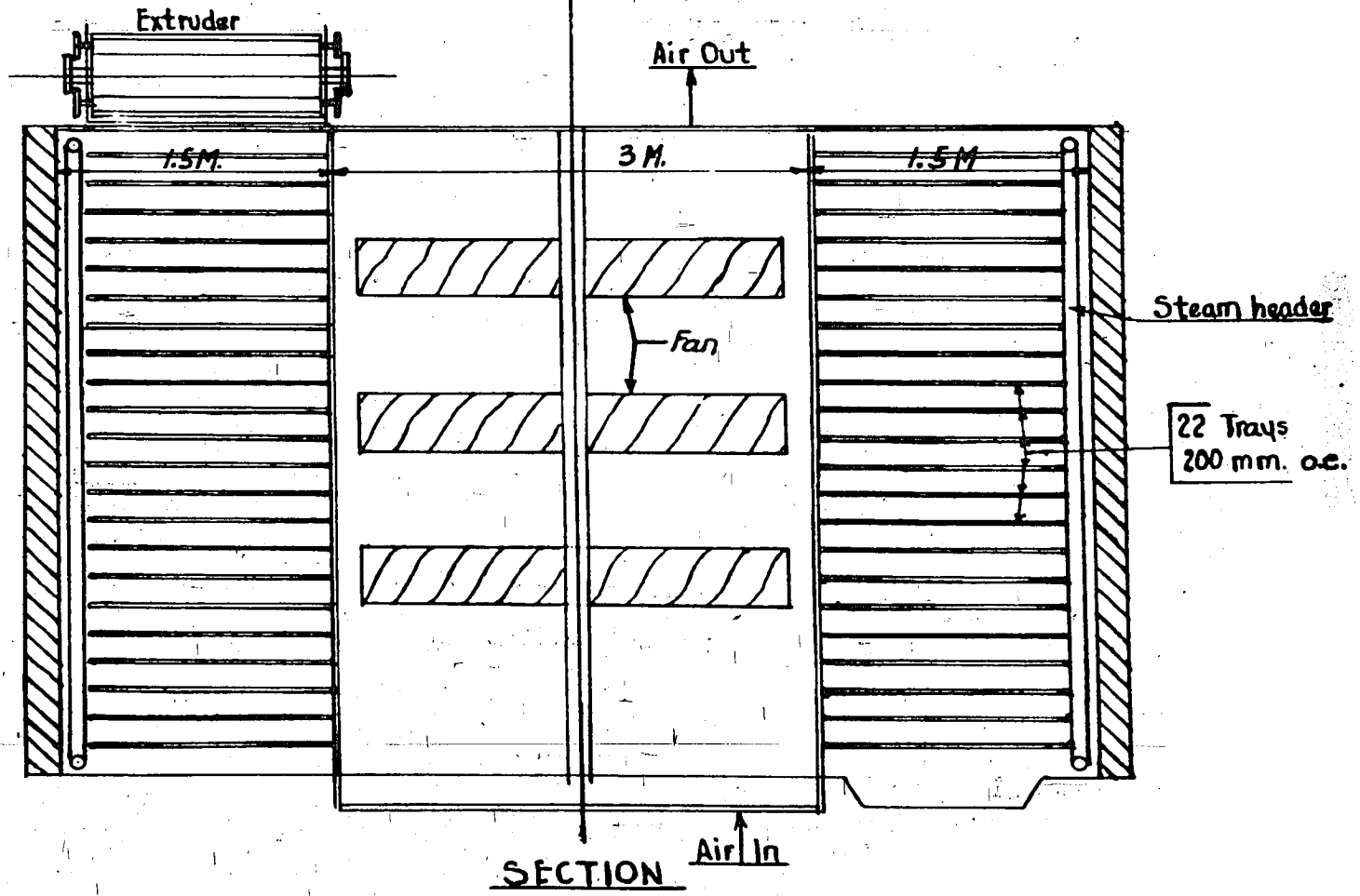

SECTION

BUTTNER DRIER

THE BITTNER DRIER

The Bittner drier, for drying the formed catalyst from the extruder, consisted of an octagonal-shaped brick frame, inside of which were steam pipes for heating the circulating air. Rotating inside of the drier were twenty-two uniformly spaced trays. Three fans were located near the center of the drier to keep the air in circulation and to blow it uniformly over the catalyst. Heated air was introduced at the bottom and left at the top of the drier. A temperature of about 212°F. was maintained throughout the drier.

Figure XXVII

154002299

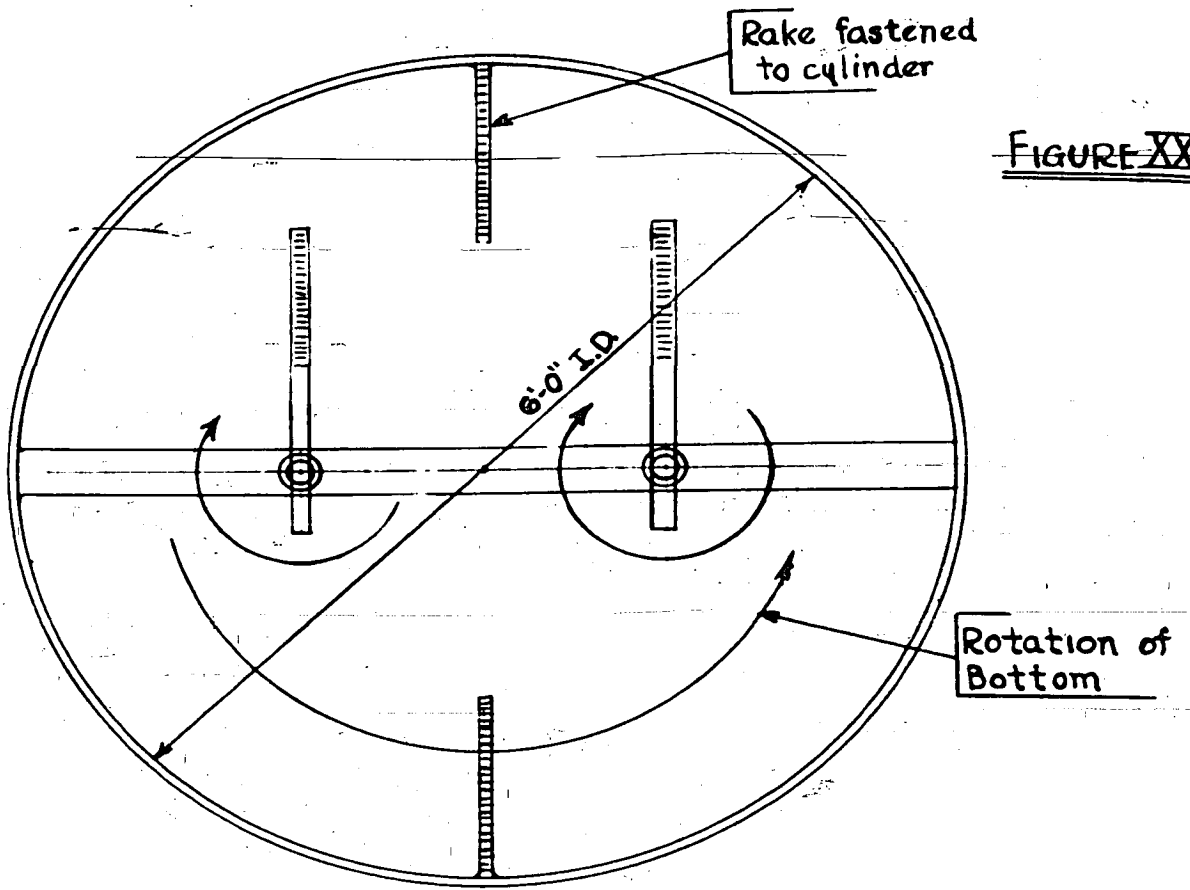
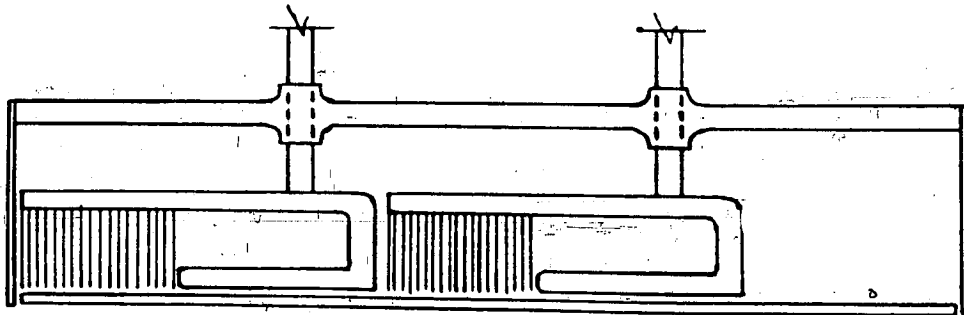

FIGURE XXVIII

PLAN



SECTION

EIRICHMISCHER

THE EIRISCHMISCHER

The Eirischmischer was used for forming the catalyst into small balls. It consisted of an upright cylinder, about six feet in diameter, provided with a rotating bottom and two scrapers and rakes, which rotated in a direction opposite to that of the bottom of the mixer. The scrapers were adjusted to have a minimum clearance between the sides of the cylinder and the bottom. Dry powdered catalyst, containing about 20-50% of coarser material (up to one millimeter) was placed in the cylinder and the mixing started. The bottom had a speed of 5 R.P.M., and the scrapers a speed of 60 R.P.M. at the start. About 50% water was sprinkled on the catalyst, and after some time the R.P.M. of both the bottom and scrapers were doubled. 70% of the charged catalyst could be recovered as sized particles.

Figure XXVIII

154002301

FIGURE XXIX
REDUCTION CHAMBER

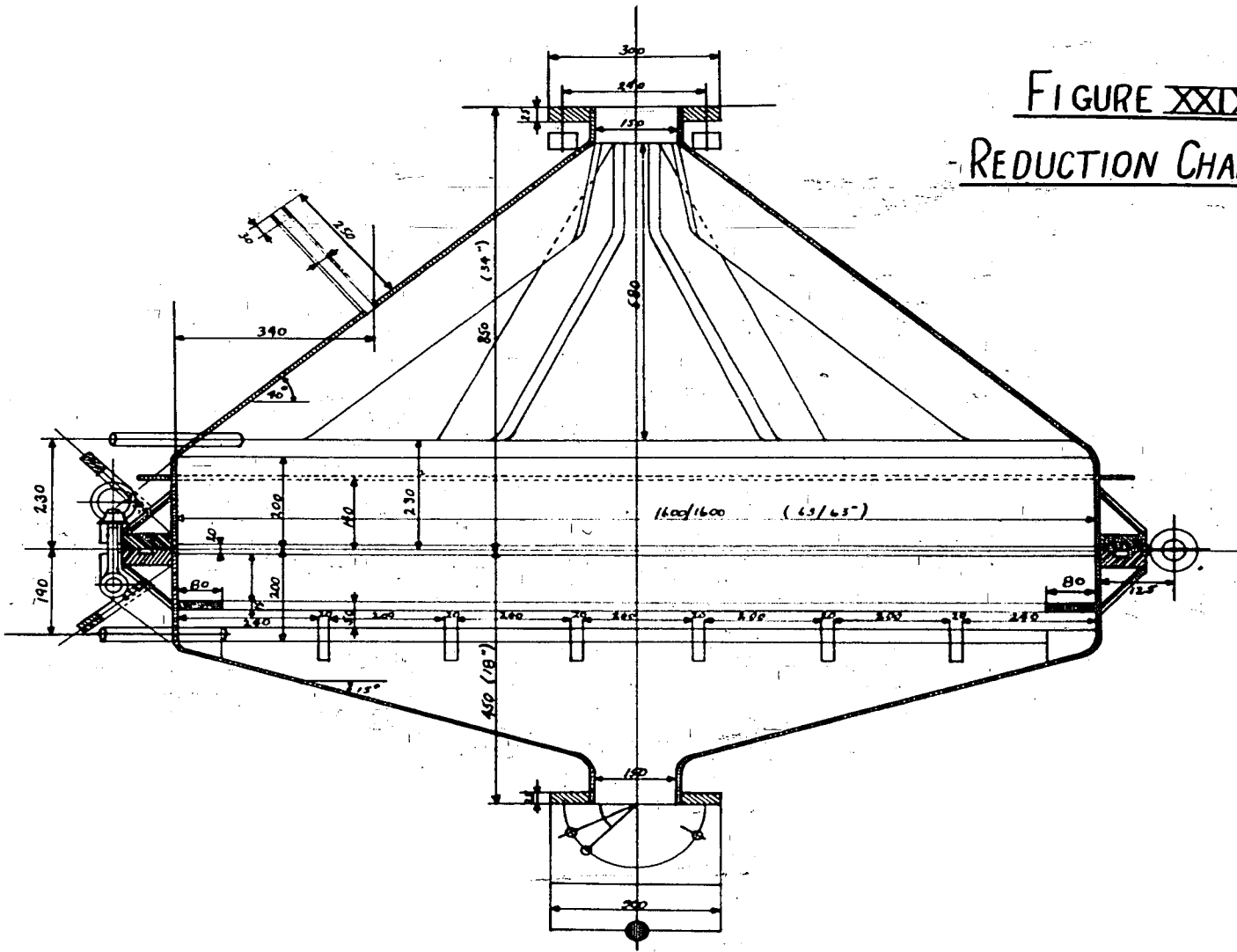

THE REDUCTION CHAMBER

The reduction chamber consisted of a square steel box, 63 inches square by 16 inches high, with a cone-shaped top and bottom section. The total height of the chamber was 52 inches. A fine screen was placed on the bottom of the square box to support the catalyst and hydrogen was introduced at the top cone section and passed downward over the catalyst. The top section was on hinges and was opened when introducing fresh catalyst. The entire chamber was on a rotating axis so that it might be inverted when removing the catalyst. The reduction chamber held about 21 cubic feet (600 liters) of catalyst and had a daily capacity of about one synthesis chamber charge--1900 pounds (850 kilograms) cobalt.

Figure XXIX

154002303

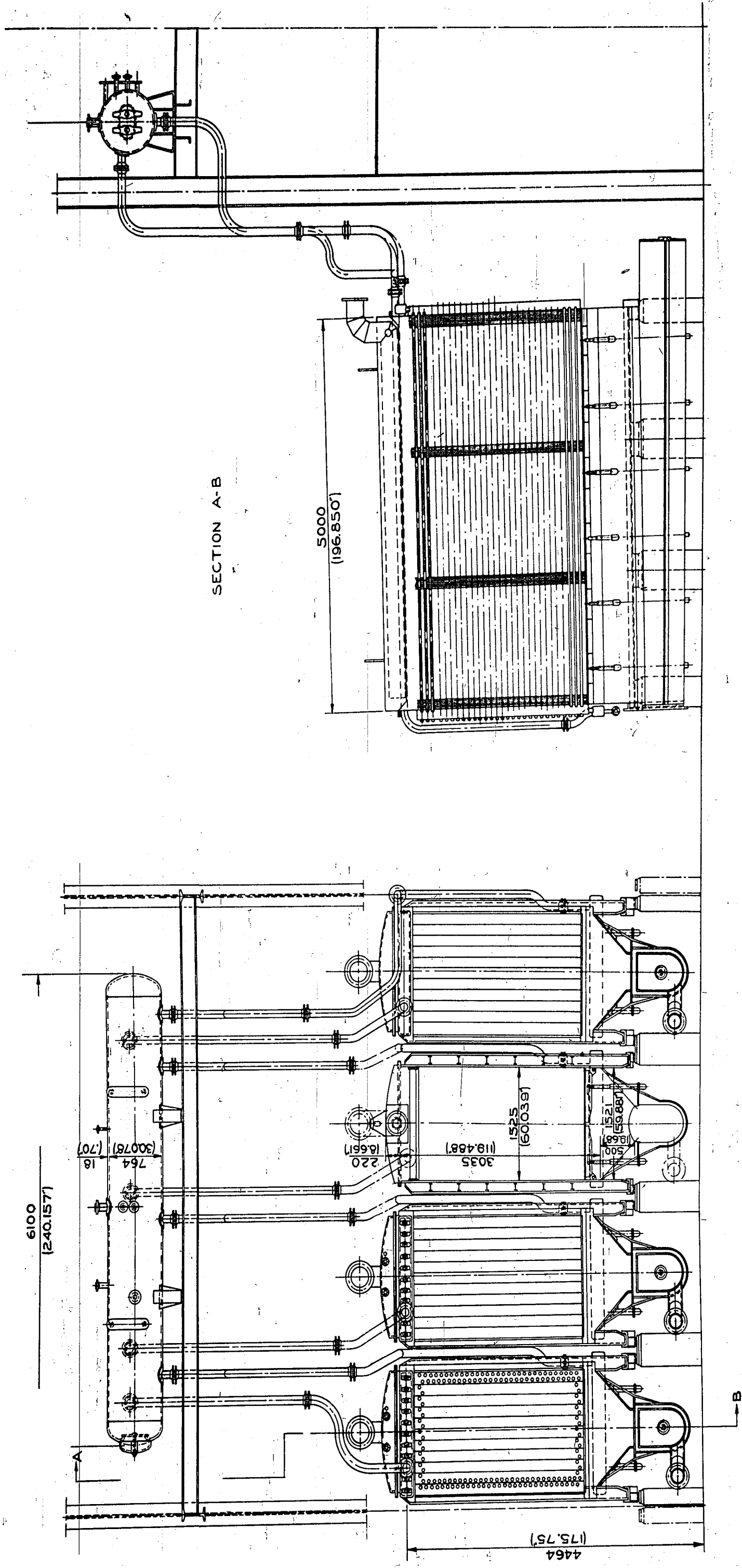

FIGURE XXX
ATMOSPHERIC
PRESSURE CHAMBERS.

REACTION CHAMBER FOR USE AT ATMOSPHERIC PRESSURE

The contact chamber for use at atmospheric pressure was in the form of a rectangular box 16 feet (5 meters) long by 5 feet (1.5 meters) wide by 8 feet (2.5 meters) deep. The cross sectional area of the chamber was therefore about 80 square feet (7.5 square meters). The total free volume of the chamber was about 440 cubic feet (12.5 cubic meters), but due to the voids only about 350-390 cubic feet (10-11 cubic meters) of catalyst could be placed in the oven. This catalyst volume corresponded to 1900-2000 pounds (850-900 kilograms) cobalt.

Figure XXX

Synthesis gas entered at the top of the synthesis chamber and passed downwards through the catalyst. The catalyst rested upon hinged screens which could be opened to enable an easy emptying of the catalyst mass. The reaction heat of the synthesis was transferred to a water-cooled pipe system and led off in the form of steam. The cooling system was therefore under pressure and was connected with a boiler drum which was fitted with the normal steam boiler accessories.

The rectangular chambers were traversed by seamless boiler tubes in horizontal direction. Vertical to the boiler tubes were steel sheets, having a thickness of about 1/16 inch (1.6 millimeters), spaced at intervals of 0.3 inches (7.4 millimeters). In order to obtain good heat transfer from the steel sheets to the boiler tubes, the latter were expanded to fit snugly into the holes in the steel sheets, by forcing a ball through the tubes. Each chamber had a total tube surface of 4300 square feet (400 square meters) and a total fin surface of 38,700 square feet (3600 square meters) for a total cooling surface of 43,000 square feet (4000 square meters).

The weight of the atmospheric pressure chamber, no insulation, was about 90,000 pounds (41 tons).

It was stated that the ideal reaction chamber would consist of water-cooled aluminum tubes 0.4 inches (10 millimeters) in diameter, with 0.03 inches (0.75 millimeters) walls and about 15 feet (4-5 meters) long. Ideally, these tubes would be filled with catalyst of the highest possible apparent density and with the highest porosity in about 0.5 millimeters particle size. It was thought that having a temperature increase along the tube in the direction of flow of the gases would be disadvantageous, since olefin production would be decreased and the yield of methane increased.

154002306

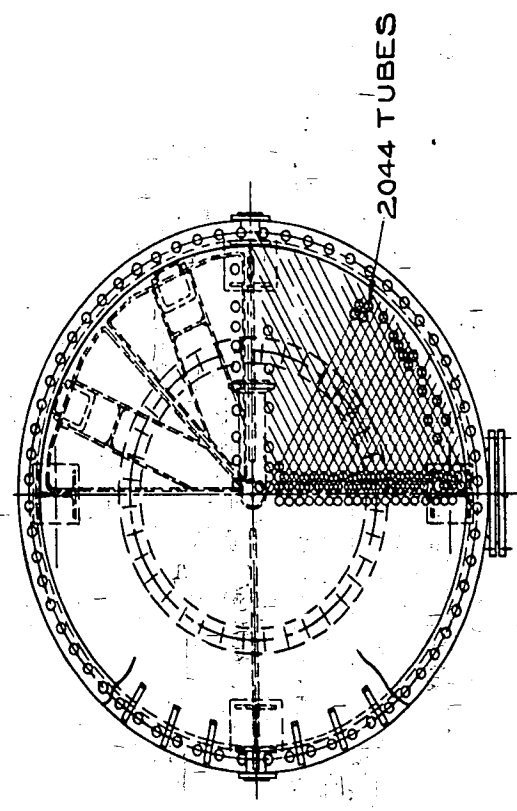
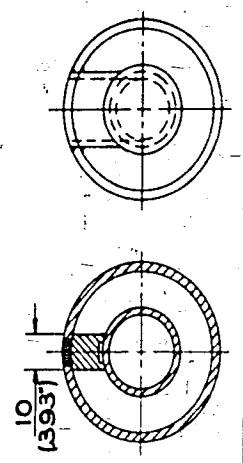
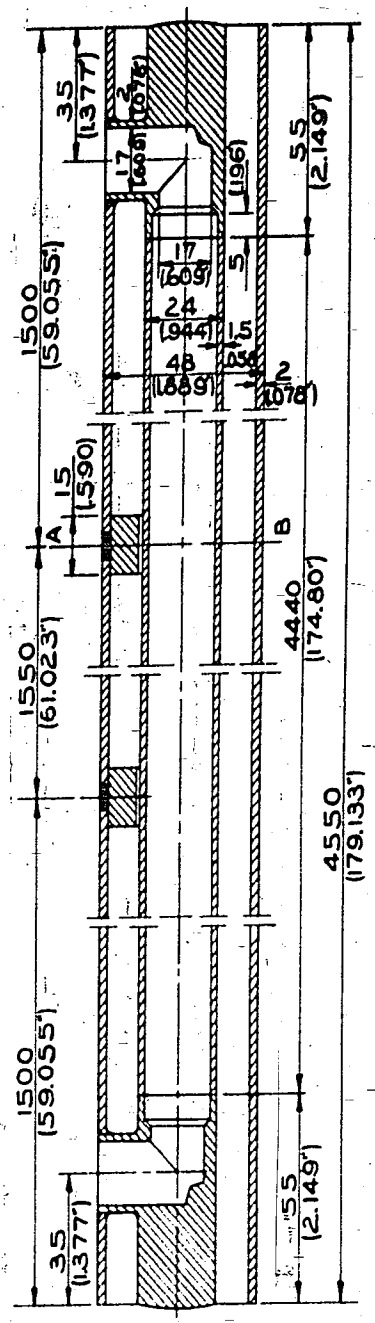
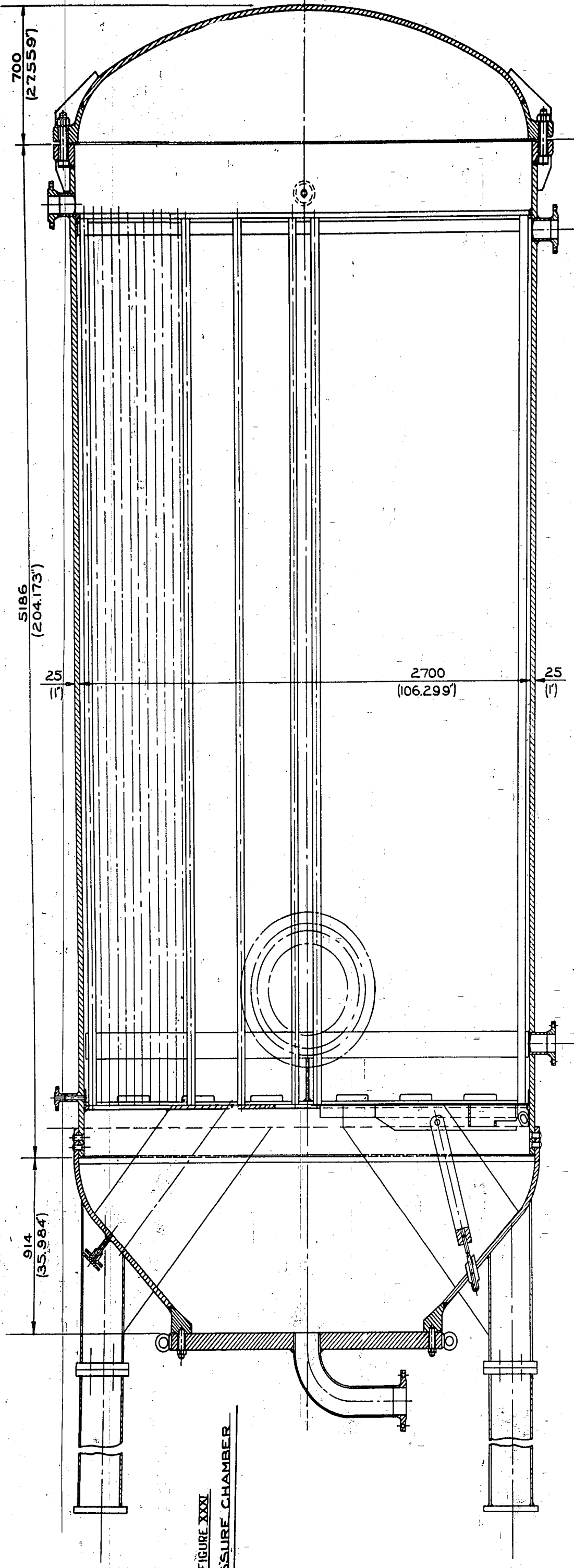

REACTION CHAMBER FOR USE UNDER PRESSUREFigure XXXI

The contact chamber for use under pressure consisted of a wrought iron cylindrical boiler in a vertical position, fitted with a double pipe system between two, top and bottom, tube sheets. The catalyst was placed in the annular spaces between the inner and outer tubes. The cooling water occupied the space around the outer tubes and flowed through the inner tubes. This cooling system appeared to be much better than the combination of fins and tubes used in the atmospheric pressure chamber. The steam accumulation system was similar to that described for the atmospheric pressure chamber.

The high pressure synthesis chamber was 9 feet (2.7 meters) in diameter, 15 feet (4.5 meters) high. It had a total volume, available for catalyst, of 350 cubic feet (10 cubic meters) and could be totally filled with catalyst. This volume corresponded to 1900 pounds (850 kilograms) cobalt.

The annular space into which the catalyst was placed was 0.4 inches (9 millimeters) wide. Each pressure chamber contained 2,044 such annular spaces. The total cooling

~~surface in the chamber was about 22,600 square feet (2100 square~~
meters). While this cooling surface was only about half that
in the atmospheric pressure chamber, the pressure chamber was
thought to be more efficient due to the fact that all the cool-
ing surface was directly in contact with water. The weight of
the iron in a pressure chamber, exclusive of insulation, con-
nections or boiler, was 108,000 pounds (49 tons).

154002309

Report by: W. E. Riblett
W. B. Johnson
G. Roberts