



DE92000793

NTIS[®]
Information is our business.

**QUANTIFICATION OF PROGRESS IN INDIRECT
COAL LIQUEFACTION. PERIOD OF PERFORMANCE,
4 APRIL 1990--31 JULY 1991**

MITRE CORP.
MCLEAN, VA

1991

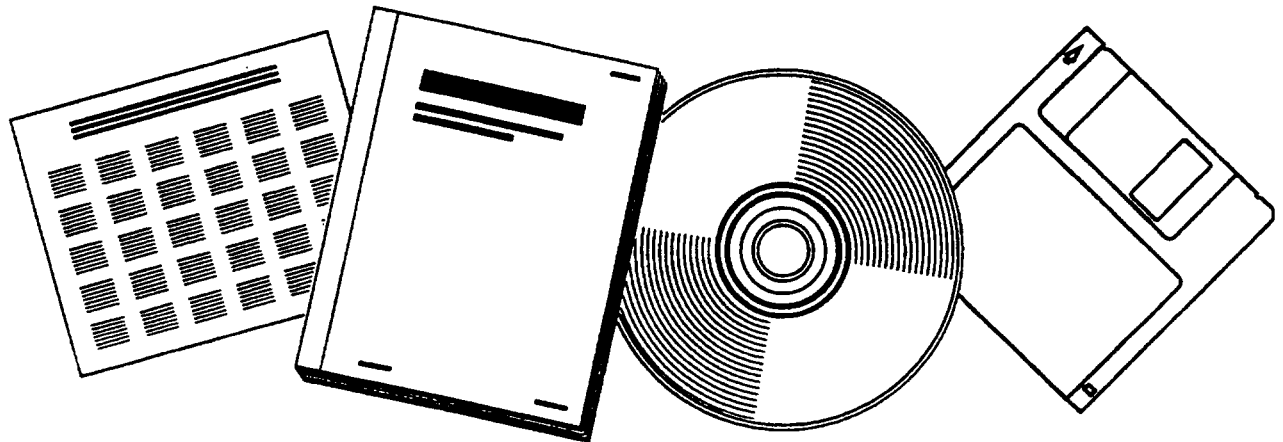

U.S. DEPARTMENT OF COMMERCE
National Technical Information Service

TITLE: QUANTIFICATION OF PROGRESS IN INDIRECT COAL LIQUEFACTION DE92 000793

AUTHORS: David Gray, Abdel ElSawy, and Glen Tomlinson

ORGANIZATION: The MITRE Corporation, 7525 Colshire Drive, McLean, VA 22102

CONTRACT NUMBER: 69-8416

PERIOD OF PERFORMANCE: 4 April 1990 - 31 July 1991

OBJECTIVE:

The objective of this study is to quantify the economic and technical impact of incorporating various advanced technologies into the indirect coal liquefaction system. These advanced technologies include entrained flow Shell gasification and slurry-phase Fischer-Tropsch (F-T) synthesis. This objective was accomplished by substituting the Shell entrained coal gasifier system for the Lurgi and the advanced slurry F-T reactor for the Synthol and ARGE F-T systems in a SASOL-type indirect liquefaction facility.

ACCOMPLISHMENTS AND CONCLUSIONS:

The indirect liquefaction of coal is practiced commercially in South Africa and produces about half of the country's gasoline and diesel fuel. The SASOL operation consists of three plants; SASOL I is a small facility but SASOLs II and III are huge complexes that together produce over 100,000 barrels per day of transportation fuels. These fuels are high quality specification gasoline and diesel and are marketed at all service station outlets throughout the country.

The indirect coal liquefaction technology used at SASOL consists of dry-bottom Lurgi fixed-bed gasifiers and predominantly Synthol circulating fluidized bed (CFB) F-T synthesis units. SASOL I also uses some fixed-bed ARGE F-T reactors for the production of high quality waxes.

Research and development in F-T technology over the past forty years has demonstrated that three-phase bubble column reactors, also called slurry reactors, potentially have many advantages over both the fixed-bed ARGE and the gas-phase fluid bed reactors. These reactors have rapid heat transfer characteristics because of the liquid slurry medium, can process low hydrogen to carbon monoxide gases such as are produced from advanced entrained gasifiers, and can operate in a temperature regime favoring production of heavier

hydrocarbons and hence very low methane and ethane yields. To overcome the selectivity limitations inherent in the F-T process that are described by the Schulz-Flory-Anderson probability model, production of heavier hydrocarbons like high molecular weight waxes followed by mild selective hydrocracking to distillate has proven to be a very effective strategy. These reactors are also structurally simple and thus they should be relatively inexpensive.

Prior to the commencement of this task, MITRE had developed an indirect coal liquefaction model that simulated the production of liquid fuels from Illinois coal using Shell gasification and slurry-phase F-T synthesis. This model was used to estimate the costs of coal-derived liquid transportation fuels. This model has also been used as a research guidance tool to investigate the impacts of research and development advances on the economics of these processes. In order to meet the objective of this current task, MITRE had to extend this model to include Lurgi gasification in place of Shell, and Synthol and ARGE F-T syntheses in place of the slurry system. Since the Lurgi system could not readily be used with a caking bituminous coal such as Illinois #6, the coal feedstock in the model was changed to a non-caking Wyoming subbituminous coal. Incorporating the significantly different Lurgi system necessitated considerable changes in the infrastructure of the conceptual plant compared to the previously developed model. However, as far as possible, the plants were configured with the same engineering consistency so that a fair comparison could be made.

Five conceptual indirect liquefaction plants were developed and investigated in this analysis. A SASOL type plant using Lurgi gasification and Synthol F-T synthesis, designated LURGSYNW; a plant using Shell gasification and Synthol designated SHELSYNW; an advanced technology plant using Shell gasification and slurry-phase F-T synthesis, designated SHELSLUW; a plant using Lurgi gasification and ARGE synthesis designated LURGARGE; and a plant using Shell gasification and ARGE synthesis designated SHELARGE. Wyoming subbituminous coal was used as feedstock in all of the cases.

The Synthol reactor system uses a fused iron F-T catalyst while the ARGE system uses a silica promoted precipitated iron catalyst. The slurry F-T system uses a precipitated iron catalyst.

The moisture in the run of mine coal was 28 percent on an as-received basis. The coal was gasified in the Lurgi gasifiers with this moisture content. However, when the Shell gasification system was used, the coal moisture was reduced to 12 percent.

DISCLAIMER

This report was prepared as an account of work sponsored by an agency of the United States Government. Neither the United States Government nor any agency thereof, nor any of their employees, makes any warranty, express or implied, or assumes any legal liability or responsibility for the accuracy, completeness, or usefulness of any information, apparatus, product, or process disclosed, or represents that its use would not infringe privately owned rights. Reference herein to any specific commercial product, process, or service by trade name, trademark, manufacturer, or otherwise does not necessarily constitute or imply its endorsement, recommendation, or favoring by the United States Government or any agency thereof. The views and opinions of authors expressed herein do not necessarily state or reflect those of the United States Government or any agency thereof.

THE LURGI/SYNTHOL (LURGSYNW) CASE:

This case represents the SASOL-type baseline plant and Figure 1 shows a block flow diagram of the Lurgi/Synthol (LURGSYNW) case. The basis for this case is taken from the Mobil Research and Development Corporation (MRDC) report⁽¹⁾. Run of mine Wyoming subbituminous coal is prepared for gasification in coal handling unit 228. The mechanical properties of the coal are such that crushing produces 83.5 percent 2" to 1/4" particles suitable for gasifier feed and 16.5 percent minus 1/4" fines. Sufficient fines are sent to the steam plant (unit 222/223) to provide the required steam and utilities for the balanced plant when they are burned together with the tar, oils and phenols from the Lurgi gasifiers. Table 1 shows the properties of the feed coal.

The purified fresh feed gas from the Rectisol unit is combined with the recycle streams in the F-T synthesis loop and passed through the Synthol reactors. The reactor effluent is cooled and the water containing the alcohols is separated from the liquid hydrocarbons. The uncondensed hydrocarbon gases and unconverted synthesis gas stream is split and a percentage is recycled to the F-T reactor and the remainder is sent to the hydrocarbon recovery unit (210) where a low temperature heptane wash is used to handle the gas since it contains carbon dioxide. The overheads from unit 210 go to carbon dioxide removal (Benfield unit 213) and the effluent gas containing the methane, ethane, ethene and unconverted synthesis gas is split so that a small stream goes to a Pressure Swing Adsorption (PSA) unit (211) to recover hydrogen for refining and plant fuel gas. The remainder of the stream is sent to the autothermal reformer where the methane is reformed to hydrogen and carbon monoxide with oxygen. This reformed stream is then recycled to the Synthol F-T units where it meets the fresh gas feed from gasification/ gas purification. Using this recycle configuration, all of the methane and ethane are converted to synthesis gas and the plant output is only liquids and propane and butane liquified petroleum gas (LPG).

The raw F-T products are fractionated in unit 252 where the C₃ and C₄ components containing about 75 percent olefins are sent to polymerization and alkylation (units 257, 258, 259). The C₅+ product is hydrotreated to remove olefins (unit 253) and fractionated to give a C₅/C₆ stream for isomerization (unit 256) and a C₇-C₁₁ stream for catalytic reforming (unit 255). The various components of the gasoline pool are blended in unit 270. The diesel component, the LPG and the alcohols are also products from the plant.

The plant also includes all other off sites necessary for integrated operations. These are boiler feed water (BFW) preparation, cooling water make-up preparation and cooling water towers, wastewater treatment etc. A steam boiler that uses coal, and Lurgi produced oils, tars and phenols is included in this configuration to provide process steam for the gasifiers and other plant units.

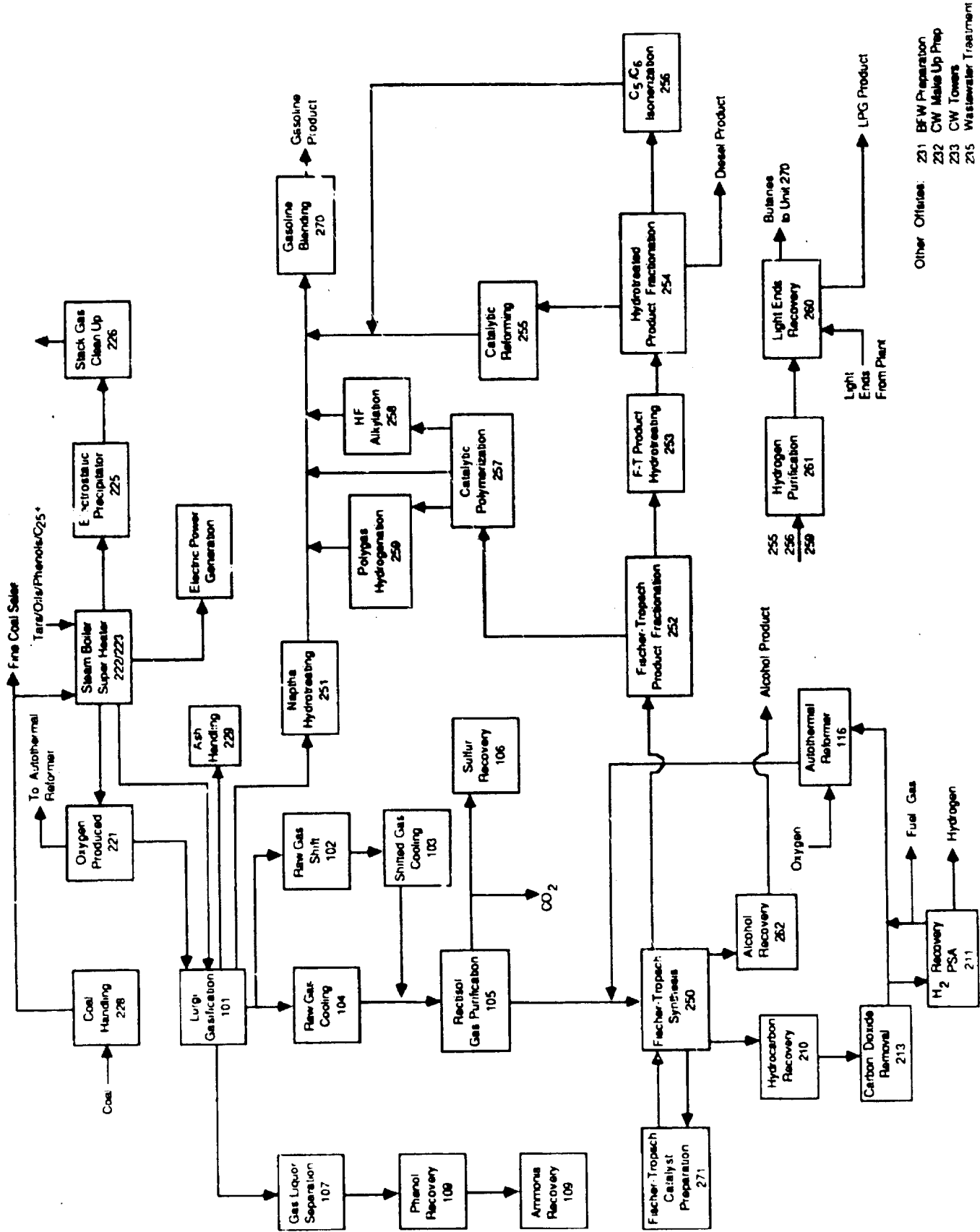

Other Offsites: 201 BFW Preparation
 222 CW Make-Up Prep
 233 CW Towers
 235 Wastewater Treatment

Figure 1. LURGI/SYNTHOL Indirect Coal Liquefaction Plant (LURGSYNW)

**Table 1. Study Coal Properties
(Wyoming Subbituminous Coal)**

Proximate Analysis, wt. %	As Received	Dry and Ash Free (DAF)
Moisture	28.0	--
Ash	5.1	--
Fixed Carbon	33.8	50.5
Volatile Matter	<u>33.1</u>	<u>49.5</u>
	100.0	100.0
Ultimate Analysis, wt. %		
C		74.45
H		5.10
O		19.25
N		0.75
S		<u>0.45</u>
		100.00
Calorific Value, Btu/lb		
High Heating Value (HHV)	8,509	12,720
Low Heating Value (LHV)	7,893	12,236

Figure 2 shows the details of the gas flows around the F-T synthesis loop. This loop includes the Synthol reactors, hydrocarbon recovery, carbon dioxide removal, autothermal reforming and hydrogen recovery PSA. As can be seen from figure 2, the fresh feed joins both the autothermal reformer recycle loop (stream #2) and the Synthol internal recycle loop (stream #3).

THE SHELL/SYNTHOL (SHELSTYNW) CASE:

Figure 3 shows a block flow diagram of the SHELSTYNW case. In this case the Lurgi gasifiers have been replaced by advanced entrained flow Shell coal gasification reactors. Wyoming coal is pulverized and dried to about 13 percent moisture and then gasified in the Shell gasifiers with oxygen. The raw gas is cooled with recycle gas to just below the ash deformation temperature and then passed to waste heat boilers to recover the sensible heat in the hot gas stream. After washing to remove particulates, a portion of the gas is raw shifted to adjust the molar hydrogen to carbon monoxide ratio and then the gas is sent to the downstream gas purification systems that include COS hydrolysis, acid gas removal, and residual sulfur removal. The clean gas is combined with the recycle streams from the Synthol and from the autothermal reformer loop and sent to the F-T Synthol reactors. The raw F-T product is upgraded in the same manner as shown in figure 1.

The plant configuration in this case differs from the previous LURGSYNW case in several aspects. Since the Shell gasifier can utilize all of the coal and does not produce oils, tars and phenols, no steam generation plant is used in this case. High quality steam is produced in the Shell gasifier waste heat boilers. This steam is used for air compression in the oxygen plant and for other plant uses. The gas purification process is also simplified in this case because no tars etc are produced. The acid gas removal system (Selexol) is also different in this case since no liquid gasifier naphtha is produced. Once the clean synthesis gas has been produced the rest of the plant configuration is similar to the previous case.

THE LURGI/ARGE (LURGARGE) CASE:

The Lurgi/Arge plant configuration is the same as case LURGSYNW (figure 1) except that the Synthol reactors are replaced with ARGE fixed-bed units. Use of the lower temperature ARGE process results in a different F-T product distribution from the Synthol case. With ARGE about 45 percent by weight of the F-T raw product is wax. Thus the addition of a wax hydrocracker is required to produce diesel and gasoline. As with the other Lurgi plant, this plant also requires a steam plant to burn the Lurgi byproducts and to raise process steam for the gasifier and other units.

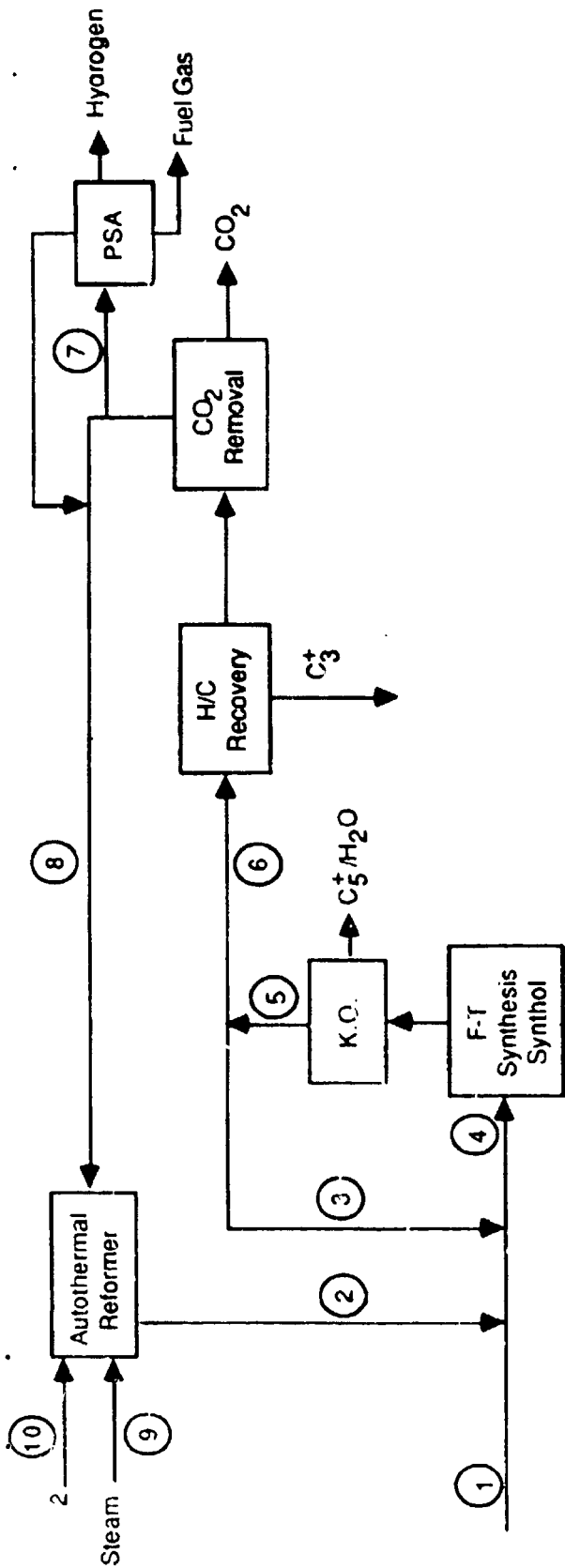

MMPH (1000 lb moles/hr)

Stream #	1	2	3	4	5	6	7	8	9	10
Description	FF	Reformer Output	Synthol Recycle	Synthol Feed	FT Tail Gas	Recovery To H/C	To PSA	Reformer Feed	Steam	Oxygen
CH ₄	29.1	3.9	80.1	113.1	120.2	40.1	3.6	39.4		
H ₂ O	0.8	85.3	1.0	87.1	1.5	0.5		0.5	69.9	
H ₂	89.4	141.7	162.5	393.6	244.0	81.5	7.3	75.3		
CO	43.9	38.9	10.9	93.7	16.3	5.4	0.5	5.3		
CO ₂	0.3	10.9	31.0	42.2	46.6	15.6		0.2		
N ₂	0.7	25.3	51.7	77.7	77.7	26.0	2.3	25.3		
O ₂										34.9
C ₂ H ₄			6.0	6.0	9.0	3.0		4.4		
C ₂ H ₆			2.0	2.0	3.0	1.0				
C ₃ /C ₄			9.8	9.8	14.7	4.9				
Totals	164.2	306.0	355.0	825.2	533.0	178.0	13.7	150.4	69.9	34.9

Figure 2. F-T Recycle Loop for Case LURGSYNW

Bechtel ⁽²⁾ has investigated an ARGE F-T design case for DOE and has conceptually designed a larger version of the SASOL ARGE fixed-bed reactor. This reactor has a capacity three times greater than the SASOL ARGE reactor with respect to total feed throughput and catalyst volume. The Bechtel design has 9602 tubes of 1.5 inch o.d. and has a diameter of 15.75 feet i.d. and a tangent to tangent length of 43 feet 9 inches. MITRE has used this Bechtel design in this analysis and has used the reactor costs estimated by Bechtel in their report. In the Bechtel design, 8 fixed-bed reactors were used to process 166 thousand pound moles per hour(MMPH) of total feed. In this case, 1080 MMPH of total feed is fed to the F-T reactors. This requires 52 reactors. The Bechtel design assumed that the fixed-bed units were packed with an active cobalt catalyst having a per pass synthesis gas conversion of 37 percent at a total feed space velocity of 1900 hour⁻¹. This study assumes an iron-based catalyst having a per pass conversion of 26 percent at the same total feed space velocity.

THE SHELL/ARGE (SHELARGE) CASE:

The Shell/ARGE plant configuration is the same as in the Shell/Synthol plant case (SHEL SYNW), see figure 3, except that ARGE reactors replace the Synthol F-T reactors. The ARGE process produces a raw product distribution containing 45 percent wax so again a wax hydrocracker is required to produce the final diesel and gasoline product slate. A gas fired superheater has been included in this design to produce sufficient plant steam to minimize electric power purchases.

THE SHELL/SLURRY (SHEL SLUW) CASE:

The Shell/Slurry F-T plant configuration is the same as the Shell/Synthol and Shell/ARGE cases except that the F-T synthesis unit is the slurry-phase system and this is used in place of the ARGE and Synthol systems. The slurry reactor raw F-T output is 48 percent by weight wax and this is hydrocracked to produce diesel and gasoline. Details of the design of a Shell/Slurry F-T case can be obtained from an earlier MITRE report⁽³⁾.

Bechtel ⁽²⁾ has also investigated slurry-phase reactor designs for the DOE in their recent report. MITRE has used the Bechtel reactor dimensions and costs in this study. The slurry reactor dimensions are 15.75 feet i.d. and 46 feet 3 inches tangent to tangent height. However, in the Bechtel design, a superficial gas velocity of 13.6 cm per second was used. In this study, it is assumed that the allowable superficial gas velocity is the 9.5 cm per second recommended by Kolbel. Using this limitation, this case requires 51 slurry reactors to process the total feed of 235 MMPH.

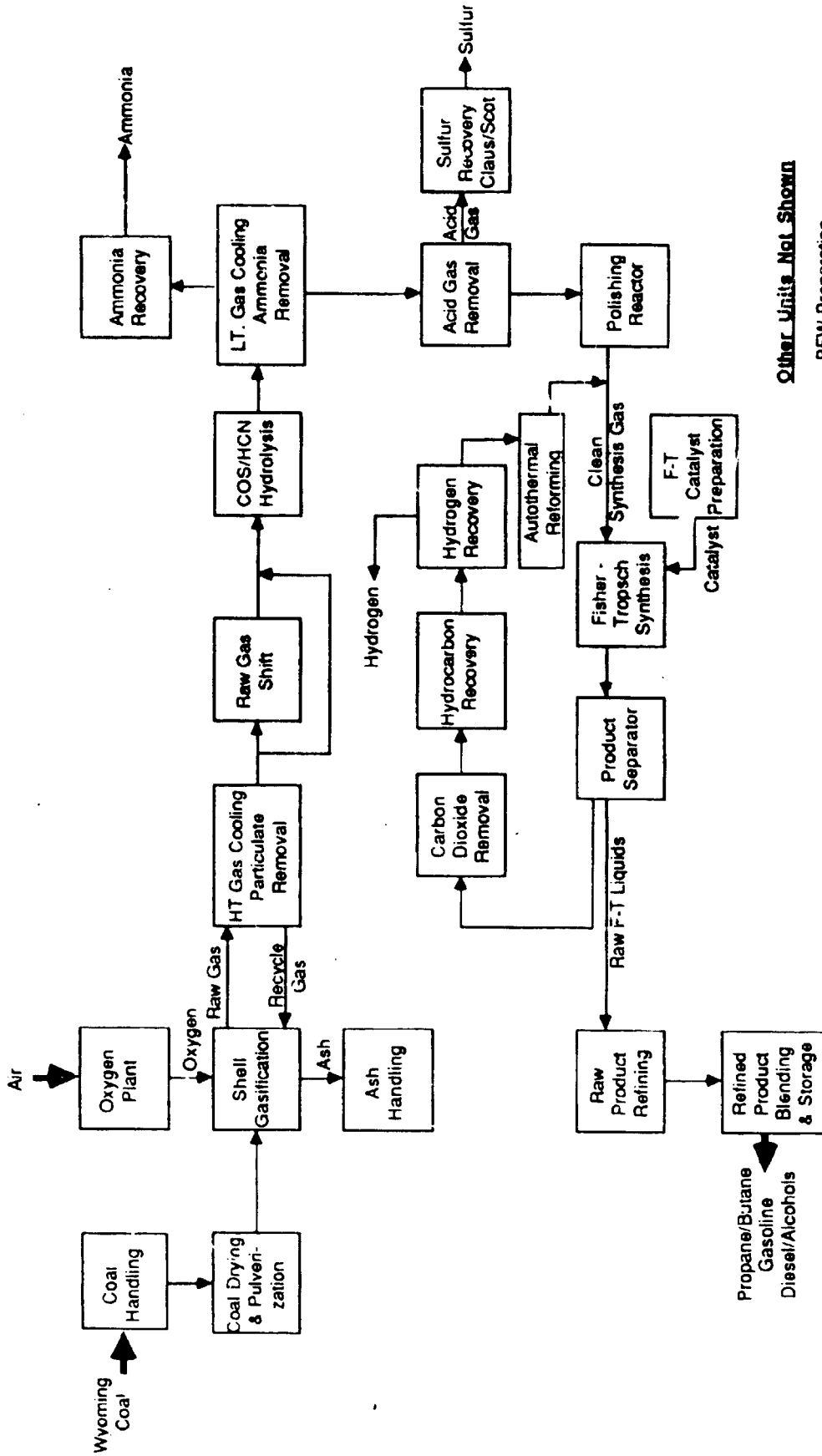

Other Units Not Shown

- BFW Preparation
- CW Make-Up Preparation
- CW Towers
- Electric Power Generation
- Waste Water Treatment
- Relief and Blow Down

Figure 3. SHELL/SYNTHOL Indirect Coal Liquefaction Plant (SHELSYNW)

COMPARATIVE ANALYSIS OF THE FIVE INDIRECT LIQUEFACTION CONFIGURATIONS:

Table 2 summarizes the results of the analyses for the five indirect liquefaction configurations investigated in this study. The configurations are shown in order of decreasing required selling price (RSP) from the SASOL-type Lurgi/Synthol plant to the advanced Shell/Slurry reactor plant.

The plant coal feed varies from 54458 TPD (as received) in the SASOL-type case LURGSYNW to 42707 TPD for the advanced SHELSLUW case. This difference in coal required to produce the same total plant output of about 83,500 barrels per stream day (BPSD) is reflected in the improvement in overall plant thermal efficiency that increases from 44 to 59 percent (HHV basis) in going from LURGSYNW to SHELSLUW. The Synthol plants produce mostly gasoline while the ARGE and Slurry plants produce about half gasoline and half diesel.

The plant construction costs are disaggregated by major plant section as shown in table 2. Gasifier costs for Lurgi dry-ash units were obtained from Mobil Research and Development Company (MRDC)⁽¹⁾ and for Shell units from Florida Power and Light Company's study of Shell-based gasification-combined cycle power plants.⁽⁴⁾ The cost basis for the F-T synthesis processes were also identified earlier. The Synthol reactor reference cost was from MRDC, the ARGE and Slurry reactor costs were from Bechtel. The balance of plant includes the following units: instrument/plant air, boiler feed water preparation, cooling water preparation, cooling towers, wastewater treatment, blowdown, storage, interconnecting piping, infrastructure and miscellaneous.

The lower costs of the Lurgi gasifiers compared to the entrained Shell gasifiers are compensated by the higher costs of the gas cleaning for the Lurgi system. The Shell system also eliminates the requirement for expensive steam generation facilities. The reforming loop costs are a function of the relative sizes of the unit operations in the recycle/ reforming loop. The details of the raw F-T product refining have also been given previously. The Synthol system does not require wax hydrocracking, whereas both ARGE and the slurry systems do.

Costs for F-T catalyst preparation are based on the MRDC report that assumes the Synthol catalyst life is 50 days and the make up rate is 2480 pounds per hour for the synthesis gas conversion of 56000 MPH. In this report, F-T catalyst preparation costs are based on the quantity of synthesis gas converted for the Synthol and ARGE cases. For the Slurry case that has a much smaller catalyst inventory based on a catalyst loading of 18.5 weight percent, the F-T catalyst preparation unit cost is based on the actual catalyst make-up rate required for a 50 day life.

Table 2. Improvements in Indirect Coal Liquefaction

Summary Table

CASE	<u>LURGSYNW</u> Lurgi + Synthol F-T	<u>LURGARGE</u> Lurgi + ARGE F-T	<u>SHELSYNW</u> Shell + Synthol F-T	<u>SHELARGE</u> Shell + ARGE F-T	<u>SHELLOW</u> Shell + Slurry F-T
CONFIGURATION:					
Coal Feed (TPSD AR)					
Gasifier	46,489	42,337	43,197	47,742	42,707
Steam Plant	<u>7,969</u>	<u>10,111</u>	<u>0</u>	<u>0</u>	<u>0</u>
TOTAL Plant Coal	54,458	52,448	43,197	47,742	42,707
Energy Input (MMBtu/hr)					
Coal	38,618	37,197	30,632	33,855	30,285
Electricity	<u>17</u>	<u>96</u>	<u>356</u>	<u>25</u>	<u>280</u>
TOTAL	38,635	37,103	30,988	33,880	30,565
Plant Outputs (BPSD)					
Alcohols	4,444	1,762	4,586	1,836	1,954
Propane LPG	7,146	4,467	7,426	4,037	4,207
Butane LPG	4,701	5,403	4,957	5,522	5,560
Gasoline	59,607	36,450	58,701	32,494	33,953
Diesel	<u>7663</u>	<u>35,419</u>	<u>7,924</u>	<u>39,617</u>	<u>37,828</u>
TOTAL	83,561	83,501	83,594	83,505	83,503
Output Energy (MMBtu/hr)	16,980	17,902	16,967	18,022	17,962
Overall Efficiency (HHV%)	44	48	55	53	59
Plant Construction Costs (\$MM1989)					
Gasification	496.64	465.15	720.53	772.80	714.80
Shift	0	0	101.15	87.17	19.90
Gas Cleaning	485.30	454.71	202.79	224.14	177.52
Syngas Reforming Loop	434.05	394.69	273.96	63.23	212.78
F-T Synthesis	415.42	441.18	409.29	403.53	333.47
Raw Product Refining	332.53	293.20	309.91	264.96	239.75
F-T Catalyst Preparation	136.17	119.83	139.21	123.26	62.99
Oxygen Plant	469.13	367.74	507.45	497.83	469.50
Coal Handling/Drying	192.83	181.96	244.53	262.27	242.58
Power Gen. and Dist.	148.29	169.13	119.20	140.16	86.05
Steam Generation	416.89	449.96	0	41.34	0
Balance of Plant	<u>467.35</u>	<u>420.05</u>	<u>366.50</u>	<u>377.01</u>	<u>323.82</u>
TOTAL Construction Cost	3,994.60	3,757.60	3,394.52	3,257.70	2,883.17
TOTAL Capital Required	6,087.99	5,723.67	5,189.11	4,988.77	4,406.45
NET Annual Operating Cost	465.91	432.33	412.86	393.71	350.68
Required Selling Price of Products (\$/bbl)					
Gasoline/Diesel	58.39	54.65	54.32	47.88	4.48
Delta Percent Change		-7.76	-6.08	-6.15	-11.28

The total plant construction costs for the five configurations in \$1989 vary from \$3995MM for LURGSYNW to \$2883MM for SHELSLUW a decrease of 28 percent. Capital costs and gross and net operating costs are also shown. The required selling price (RSP) of the final gasoline and diesel products are calculated from standard economic parameters and by assuming that the relative prices of alcohols and LPG retain their levels as of September 1988 (38 percent of the price of gasoline and diesel on a \$ per barrel basis). The standard economic parameters are: 75:25 debt to equity ratio, 25 year project life, 34 percent income tax rate, no price escalation above general inflation, 3 percent general inflation, 15 percent return on equity, 8 percent interest on debt and 5 year construction period.

This comparative analysis of the five plant configurations has shown the potential reduction in the RSP of gasoline and diesel by using an entrained coal gasifier with a slurry-phase F-T synthesis system and advanced raw product upgrading to be about 28 percent compared to a SASOL-type plant. However, the performance of the slurry F-T process has only been demonstrated at a small scale. Larger scale operation is essential to demonstrate the performance of a slurry unit with respect to both hydrodynamics and catalyst kinetics.

PLANS:

MITRE will continue to evaluate those factors that have the potential to improve the technology and economics of slurry-phase reactor systems for the production of hydrocarbons and oxygenates.

ACKNOWLEDGEMENT:

This work performed at The MITRE Corporation was supported by Sandia National Laboratories, which is funded by the U.S. Department of Energy under Contract DE-AC04-76DP00789.

List of References

1. Schreiner, M., August 1978, *Research and Guidance Studies to Assess Gasoline from Coal by Methane-to-Gasoline and Sasol-type Fischer-Tropsch Technologies*, FE-2447-13, Princeton, NJ: Mobil Research and Development Corporation.
2. Fox, J. M., B. D. Degen, G. Cady, F. D. Deslate, and R. L. Summers, June 1990, *Slurry Reactor Design Studies: Slurry vs. Fixed-Bed Reactors for Fischer-Tropsch and Methanol*, Final Report prepared for U.S. Department of Energy by Bechtel, DOE/PC/89867-T2.
3. Gray, D., G. C. Tomlinson, October 1990, *Assessing the Economic Impact of Indirect Liquefaction Process Improvements: Volume 1, Development of the Integrated Direct Liquefaction Model and Baseline Case*, Sandia Contractor Report Number SAND 89-7089.
4. Florida Power and Light Company's Study of Shell-based GCC Power Plants. EPRIGS-6176. Report prepared by FPL, Fluor, Shell, and General Electric for FPL and EPRI, January 1989.

END

**DATE
FILMED**

11 106191

