

RECEIVED
DEC 02 1998
OSTI

**Task 6.5/6.7.1 - Materials for Gas Separation and Hydrogen
Separation Membranes**

**Semi-Annual Report
July 1 - December 31, 1997**

**By:
John P. Hurley
Patricia L. Kleven**

Work Performed Under Contract No.: DE-FC21-93MC30097

For
U.S. Department of Energy
Office of Fossil Energy
Federal Energy Technology Center
P.O. Box 880
Morgantown, West Virginia 26507-0880

By
Energy & Environmental Research Center
University of North Dakota
P. O. Box 9018
Grand Forks, North Dakota 58202-9018

DISCLAIMER

This report was prepared as an account of work sponsored by an agency of the United States Government. Neither the United States Government, nor any agency thereof, nor any of their employees makes any warranty, express or implied, or assumes any legal liability or responsibility for the accuracy, completeness, or usefulness of any information, apparatus, product, or process disclosed or represents that its use would not infringe privately owned rights. Reference herein to any specific commercial product, process, or service by trade name, trademark, manufacturer, or otherwise does not necessarily constitute or imply its endorsement, recommendation, or favoring by the United States Government or any agency thereof. The views and opinions of authors expressed herein do not necessarily state or reflect those of the United States Government or any agency thereof.

EERC DISCLAIMER

LEGAL NOTICE This research report was prepared by the Energy & Environmental Research Center (EERC), an agency of the University of North Dakota, as an account of work sponsored by the U.S. Department of Energy. Because of the research nature of the work performed, neither the EERC nor any of its employees makes any warranty, express or implied, or assumes any legal liability or responsibility for the accuracy, completeness, or usefulness of any information, apparatus, product, or process disclosed, or represents that its use would not infringe privately owned rights. Reference herein to any specific commercial product, process, or service by trade name, trademark, manufacturer, or otherwise does not necessarily constitute or imply its endorsement or recommendation by the EERC.

ACKNOWLEDGMENT

This report was prepared with the support of the U.S. Department of Energy (DOE), Federal Energy Technology Center, Cooperative Agreement No. DE-FC21-93MC30097. However, any opinions, findings, conclusions, or recommendations expressed herein are those of the author(s) and do not necessarily reflect the views of the DOE.

TABLE OF CONTENTS

LIST OF FIGURES	i
1.0 BACKGROUND	1
2.0 OBJECTIVES	1
3.0 STATEMENT OF WORK	2
4.0 ACCOMPLISHMENTS	2
4.1 Description and Operation of the Electron-Beam Coating Instrument	2
4.2 Deposition Tests	4
5.0 CONCLUSIONS AND FUTURE PLANS	5

LIST OF FIGURES

1 Schematic of the electron-beam coating instrument	3
---	---

TASK 6.5/6.7.1 – MATERIALS FOR GAS SEPARATION AND HYDROGEN SEPARATION MEMBRANES

1.0 BACKGROUND

Catalytic gasification of coal to produce H₂- and CH₄-rich gases for consumption in molten carbonate fuel cells is currently under development; however, to optimize the fuel cell performance and extend its operating life, it is desired to separate as much of the inerts (i.e., CO₂ and N₂) and impurities (i.e., H₂S and NH₃) as possible from the fuel gas before they enter the fuel cell. In addition, the economics of the integrated gasification combined cycle (IGCC) can be improved by separating as much of the hydrogen as possible from the fuel, since hydrogen is a high-value product. One process currently under development by the Energy & Environmental Research Center (EERC) for accomplishing this gas separation and hot-gas cleanup involves gas separation membranes. These membranes are operated at temperatures as high as 800°C and pressures up to 300 psig. Some of these membranes can have very small pores (30–50 Å), which inefficiently separate the undesired gases by operating in the Knudsen diffusion region of mass transport. Other membranes with smaller pore sizes (<5 Å) operate in the molecular sieving region of mass transport phenomena. Dissolution of atomic hydrogen into thin metallic membranes made of platinum and palladium alloys is also being developed.

Technological and economic issues that must be resolved before gas separation membranes are commercially viable include improved gas separation efficiency, membrane optimization, sealing of membranes in pressure vessels, high burst strength of the ceramic material, pore thermal stability, and material chemical stability. Hydrogen separation is dependent on the temperature, pressure, pressure ratio across the membrane, and ratio of permeate flow to total flow.

2.0 OBJECTIVES

The objective of Subtask 6.7.1 is to develop and test superior gas separation membranes. Several methods are to be tested to prepare new membrane materials, including physical vapor deposition via electron-beam evaporation. The selectivity of these membrane materials for separating undesired gases was to be determined. Selectivity will be measured by feeding the gases to the membrane and sampling the inlet, permeate, and raffinate streams for gas composition and volumetric flow rate.

Specific questions to be answered include the following:

- What are the effects of ceramic membrane properties (i.e., surface area, pore size, coating thickness) on permeability and selectivity of the desired gases?
- What are the effects of operating conditions (i.e., temperature, pressure, and flow rate) on permeability and selectivity?

3.0 STATEMENT OF WORK

Several methods for preparing a membrane material, including physical vapor deposition via electron-beam evaporation, are to be tested. Other ceramic filter materials utilized in hot-gas particulate filters will be obtained from selected suppliers as substrates to develop a thin-film membrane selective to hydrogen permeation. This thin-film membrane will be prepared by a modified EERC proprietary process. The base filter materials will already have been characterized for hydrothermal and chemical stability and pore size.

4.0 ACCOMPLISHMENTS

A literature review conducted in the first part of the project year suggested that the most likely choice for a successful high-temperature membrane for hydrogen separation from a gasification product stream would be a ceramic analog of a dense metal membrane, where the hydrogen would dissolve into and diffuse through the membrane structure. An oxygen-deficient aluminosilicate membrane or a variant thereof appears promising, since an *n*-type semiconductor character is favorable for the chemisorption of H₂. The membrane layer would likely have to be very thin for appreciable amounts of hydrogen to diffuse through it.

Initial metal film coating tests were performed using an electron-beam coating instrument, with zinc films successfully applied to glass substrates. Preliminary experiments to test the feasibility of reacting zinc thin films with sulfur to form zinc sulfide were performed. Initial observations indicated little or no reaction occurred at the relatively mild conditions employed.

An alternative method of production of zinc sulfide thin films by direct evaporation and deposition of zinc sulfide onto substrate surfaces was tested. Uniform thin films were produced on glass substrates for testing the zinc sulfide stability in a gasification atmosphere at an elevated temperature. Samples of the thin films were heated to 400°C; exposed to atmospheres of air, carbon dioxide, and a carbon monoxide-carbon dioxide-hydrogen blend for periods of 10 hours; and subsequently examined using a scanning electron microscope (SEM). SEM microprobe analysis of Zn and S peak ratios indicated little degradation after exposure to air or the CO-CO₂-H₂ blend at the elevated temperature.

Extensive damage to the electron-beam coating instrument resulted from the flooding experienced in April, 1997, preventing production of membranes for testing until the unit was repaired and causing an approximate 6-7 month delay in the project schedule. Repairs to the unit have been completed, with the first membrane production planned for January, 1998.

4.1 Description and Operation of the Electron-Beam Coating Instrument

The coating instrument is a CHA Industries high-vacuum deposition and pumping station designed for both research or production electron-beam coating applications. A schematic of the system is shown in Figure 1. The heart of the instrument is an 18-inch-diameter × 26-inch-high-vacuum bell containing a Sloan Technology Corporation 270° electron-beam gun able to operate

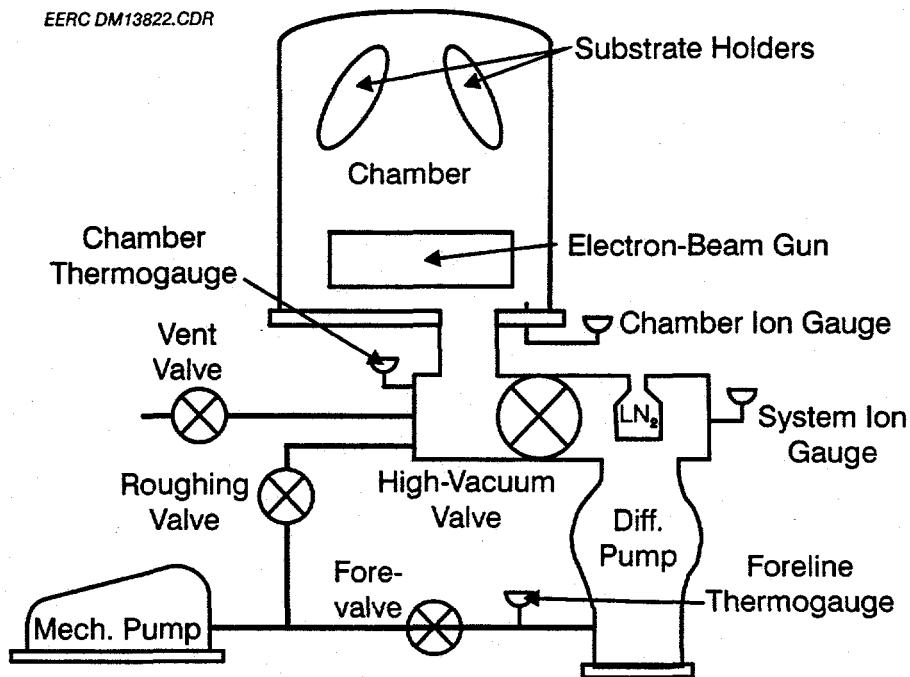

Figure 1. Schematic of the electron-beam coating instrument.

at power levels up to 12 kilowatts, with the beam directed into a water-cooled hearth containing the material to be evaporated and deposited. Substrates to be coated are held in a CHA Industries rotary planetary fixture, which permits a controlled, even film deposition. Quartz lamps around the periphery of the fixture track allow controlled heating of the substrates. A mechanical roughing pump and a diffusion pump along with associated valving provide the high vacuum necessary for operation.

Two modifications to the instrument have been made, the first being a holder containing four microscope slides positioned inside the bell in front of the observation window. The disposable slides provide a sacrificial surface, considerably reducing the amount of deposition on the viewport glass itself. A second modification was the provision for purging the bell with dry nitrogen prior to vacuum pumpdown and while being brought up to atmospheric pressure after deposition tests. This reduces possible reaction of the films produced with air, as well as preventing moisture condensation on the walls of the water-cooled vacuum bell.

In operation, the material to be deposited is loaded into a crucible fitted in the electron gun hearth. Substrate plates to be coated are mounted to the rotary fixture. After verification that cooling water flows are adequate, the vacuum bell is lowered onto the baseplate over the gun and fixture assembly. The bell is purged with a flow of nitrogen for approximately 10–15 minutes before the mechanical roughing pump is started. The system is pumped down to approximately 1×10^{-1} torr (vacuum bell) to 8×10^{-2} torr (forechamber and diffusion pump) and the mechanical pump stopped briefly to check for leakage. Significant vacuum deterioration requires repressurizing and reseating the vacuum bell to improve the seal as well as cycling the forevalve

and high-vacuum valve to improve sealing. When satisfactory sealing has been achieved, the diffusion pump is started and allowed to warm up for approximately 1 hour, with the large high-vacuum valve into the chamber closed. At this time, the liquid nitrogen trap serving the diffusion pump is filled. The mechanical roughing pump remains on, drawing both on the vacuum bell chamber and on the exhaust (forechamber) of the diffusion pump. The roughing valve is then closed, isolating the roughing pump from the bell chamber, and the high-vacuum valve opened. This allows the diffusion pump to draw from the bell chamber, with the roughing pump drawing only on the diffusion pump exhaust. The diffusion pump is operated for an hour, with the two thermogauge vacuum readings generally in the 8×10^{-2} torr range. The ion gauge is then turned on to verify that high vacuum is present in the bell chamber (a pressure greater than 1×10^{-3} torr will cause the ion gauge to immediately turn off). The ion gauge is switched to the "degas" setting for approximately 15 minutes before it is switched back to the measurement position. Normal bell chamber pressures are in the range of 1×10^{-6} to 5×10^{-6} torr.

With the bell chamber at a stable high vacuum, deposition tests using the electron beam coater are ready to commence. The power connection to the electron gun is plugged in and the control unit activated. Operation will only occur when safety interlocks verifying cooling water pressure, air pressure, high bell chamber vacuum, and instrument cabinet panel closures are correct. At this time, the quartz heat lamps may be turned on and the rotary fixture started, bringing the substrates uniformly to the desired temperature. The electron beam is kept at minimum power and directed to the center of the crucible containing the material to be evaporated using the x- and y-position controls. The beam appears as a dull violet fluorescence on the material surface. Beam power is increased with adjustments to the position as needed while the material is heated (in the case of a metal to the melting point). An indication of material evaporation is provided by the clouding of the sacrificial microscope slides protecting the viewport. In the future, a quartz film thickness monitor will be installed to accurately measure film deposition rates. The metal shutters shielding the substrates from the evaporating material in the electron beam gun crucible are then opened for a timed interval for deposition to occur. The shutters are then closed, the electron beam reduced to minimum power, the control unit switched off, the gun system unplugged, and the quartz heaters and rotation motor turned off.

Before the bell chamber is brought back to ambient pressure, the ion gauge and the diffusion pump are turned off. The diffusion pump is allowed to cool to ambient temperature with the roughing vacuum pump on and the high-vacuum valve closed before the chamber is vented to atmosphere. The roughing pump is then turned off, and dry nitrogen is introduced by the vent valve being opened into the bell chamber. When the chamber is at atmospheric pressure, the bell is raised to remove the coated substrates. Other instrument components, such as the thermopressure gauges, are turned off and the water and air supplies closed.

4.2 Deposition Tests

The initial metal thin-film deposition tests were performed using metallic zinc as the material to be evaporated, with conventional glass microscope slides as substrates. These tests were planned to gain experience with the operation of the electron-beam coating instrument as

well as provide thin films to test the feasibility of conversion of the zinc film to zinc sulfide by deposition of a sulfur overlayer with subsequent reaction of the two materials.

Glass slides serving as substrate were uniformly coated with a relatively thick, mirrored silver grey film of zinc, which adhered well to the glass. An overcoating of sulfur was applied to the zinc film of test slides under low vacuum by sublimation at approximately 110°C. There was little or no reaction of the zinc with the sulfur overcoating. Subsequent additional tests produced essentially the same results.

An alternative method of production of zinc sulfide thin films by direct evaporation and deposition of zinc sulfide onto substrate surfaces was tested. The higher sublimation point (1185°C) of ZnS required a higher electron-beam intensity. Other test parameters, such as vacuum levels, remained unchanged. Uniform thin films were produced on glass substrates for testing the zinc sulfide stability in a gasification atmosphere at elevated temperature.

Samples of the thin films were heated to 400°C and exposed to atmospheres of air, carbon dioxide, and a carbon monoxide-carbon dioxide-hydrogen blend for periods of 10 hours. The films before and after exposure to the atmospheres were examined with an SEM. The films were uniform in appearance, with no apparent cracks or porosity visible at 1-10- μ m resolution. SEM microprobe analysis of Zn and S peak ratios indicated little degradation after exposure to air or the CO-CO₂-H₂ blend at the elevated temperature. The presence of hydrogen appears to stabilize the zinc sulfide against the kind of degradation that occurred in the pure carbon dioxide atmosphere. It is expected that the presence of hydrogen sulfide in a gasification atmosphere will further stabilize the coatings. Several porous ceramic and metal filter materials to serve as substrates have been obtained for coating with zinc sulfide. A test apparatus has been designed to hold the membranes to perform initial permeability testing.

5.0 CONCLUSIONS AND FUTURE PLANS

The most promising ceramic membrane for future testing of high-temperature hydrogen separation from a gasification product stream has been determined: a ceramic analog of a dense metal membrane, where the hydrogen would dissolve into and diffuse through the membrane structure. An oxygen-deficient amorphous membrane such as an aluminosilicate or other material appears promising.

Initial ZnS film coating tests have been performed using the instrument, with zinc films successfully applied to glass substrates. The coatings appear relatively stable in air and in a simple simulated gasification atmosphere at an elevated temperature. Preparation of films on several ceramic and metal membrane substrates for initial permeability testing will resume now that repair of the electron-beam coating instrument is complete, with the construction of a device to hold the membrane substrates and conduct permeability testing under way.