

87-073621/11
UHDE GMBH

E36 H04

UHDE 11.09.85
*DE 3532-413-A

E(11-H, 31-A1) H(4-E4, 5-C) N(6)

11.09.85-DE-532413 (12.03.87) C01b-03/38

Appts. for synthesis gas prodn. by steam reforming and partial oxidn. - in which inlets for further hydrocarbon and oxygen for partial oxidn. are arranged to provide vortexing and intensive mixing
C87-030642

flowing away outwards and then round the reformer tubes before leaving the reforming section (1) through outlet branches (19). The heat for the endothermic reaction is thus supplied to the reformer tubes.

USE/ADVANTAGE

The appts. can be used with natural gas, naphtha or refinery gas feedstocks. Flow behaviour in the partial oxidn. section (2) (mixing chamber) is defined. A vortex parallel to the axis is set up with a reduced-pressure region at its centre, which aids the flow of gas out of the reformer tubes and then its intensive mixing with the further hydrocarbons and O_2 .

PREFERRED ARRANGEMENT

The inlets in the wall of the partial oxidn. section make an angle of 1-30 (esp. 5-20) $^\circ$ with the radius, and +5 to -15 (esp. 0 to -10) $^\circ$ with the radial plane. The distance h of the line connecting two inlets to the plane of the reformer tube ends (i.e. approximately the vertical distance between inlets and tube ends) is 0.15 to 1 times the enclosing dia. of

DE3532413-A+

Appts. for synthesis gas prodn. at high pressure from hydrocarbons includes a catalytic endothermic reforming section (1) comprising part of a cylindrical pressure vessel and many externally-heated catalyst-filled reformer tubes (6), which a mixt. of hydrocarbons and steam enters at a tube plate (25), while a reformer gas leaves the tubes by their free ends (8). These ends project into a partial oxidn. section (2), comprising the closed-ended, increased-dia. remainder of the same pressure vessel, to which also more hydrocarbons and O_2 or O_2 -contg. gas are fed. Into the cylindrical wall of the partial oxidn. section (2) are fitted inlets (10) for hydrocarbons and/or O_2 or O_2 -contg. gas, whose axes are arranged at an angle to the radius and parallel or inclined to the radial plane, and whose distance from the outlet ends of the reformer tubes is such that a rotary loop flow of the gases is set up in the partial oxidn. section, the prod. gas

the bundle of reformer tubes. The distance h , the dia. d of a gas outlet at the reformer tube end and the largest spacing t of all these gas outlets satisfy the equation

$$t \leq d + 0.317 \times h$$

The characteristic Reynolds number at the reformer tube outlet ends is greater than 5000 (esp. greater than 50,000). (11pp1492RKMHDwgNo1/5).

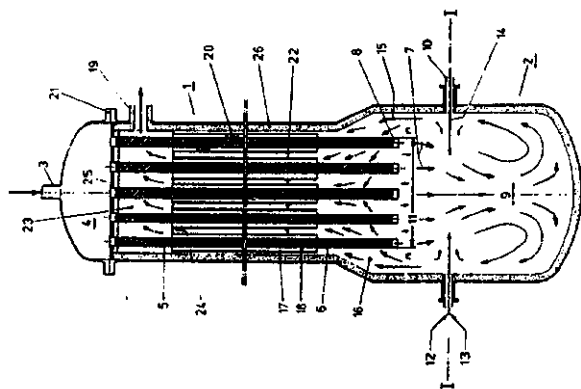

DE3582413-A