

(11) (A) No. 1,117,442

(45) ISSUED 820202

(52) CLASS 183-4  
C.R. CL. 165-2;  
260-678.6

(51) INT. CL. B01D 19/00,  
B01J 19/00<sup>3</sup>

(19) (CA) **CANADIAN PATENT** (12)

(54) APPARATUS FOR SEPARATING GAS AND LIQUID,  
SLURRY REACTOR EQUIPPED WITH THE APPARATUS  
AND SYNTHESIS PROCESS USING THE SLURRY  
REACTOR

(72) McEwan, Malcolm W.;  
Teekens, Marius B.,  
Netherlands

(73) Granted to Shell Canada Limited  
Canada

(21) APPLICATION No. 295,404

(22) FILED 780120

(30) PRIORITY DATE Netherlands (7702162) 770301

No. OF CLAIMS 14

FEB 2 1982

ABSTRACT

1117442

Apparatus for separating gas and liquid, comprising a central upflow tube which at the top opens, via an overflow edge, into a separator hood fitted over and around the top and having a gas outlet above and a liquid outlet below the overflow edge. The overflow edge is formed by a system of partitions which divide the space in the separator hood above the upflow tube and the space next to it into two kinds of compartment, - open at the top - each compartment extending in the space over the upflow tube and in the space next to it, the compartments consisting of risers or downcomers. A riser and a downcomer are side by side and have one partition in common. Slurry reactor comprising the above apparatus. Synthesis process using the slurry reactor.

# 1117442

The invention relates to an apparatus for separating gas and liquid, comprising a central upflow tube which at the top opens, via an overflow edge, into a separator hood fitted over and around the top of the upflow tube and having a gas outlet above the overflow edge and a liquid outlet below the overflow edge, but outside the upflow tube.

The simplest embodiment of such an apparatus is the one in which the upflow tube is cylindrical and the overflow edge is formed by the upper edge of the upflow tube. Such an embodiment has been described for instance in French Patent 7,437,051.

10            Now, it has been found that the degree to which a separation between gas and liquid is effected by means of the above-mentioned apparatus depends on the combined effect of a residence of the phases to be separated in the separator hood and of the movement of the phases over the overflow edge. In certain applications - for instance in the synthesis of hydrocarbons from synthesis gas in a slurry-type reactor in which the catalyst is suspended in recycled liquid product or in a circulating auxiliary liquid and in which liquid and catalyst, after having been separated from unconverted gas and gaseous by-products at the top of the upflow reactor, are cooled outside the reactor and recycled to the bottom of the reactor - it has been  
20            found, when using the above-mentioned simplest embodiment of the separating device, that the effect of the circular overflow edge alone does not bring about an adequate separation. The separation then has to be completed in the space of the separator hood outside the upflow tube where below the overflow edge a liquid level must be maintained with a very large surface area. This calls for an outer diameter of the separator hood many times larger than that of the upflow tube - in this case the reactor - which is found to be unacceptable in practice.

30            The present invention aims at solving this problem and therefore proposes, instead of enlarging the liquid surface area in the separator hood, to lengthen the overflow edge.

            Thus, according to the invention there is provided an apparatus for separating gas and liquid, comprising a central upflow tube which at the

C

# 1117442

top opens, via an overflow edge, into a separator hood fitted over and around the top of the upflow tube and containing a wall and having a gas outlet above the overflow edge and a liquid outlet below the overflow edge, but outside the upflow tube, characterized in that the overflow edge is formed by a system of partitions which traverse the space directly above the upflow tube and continue in the radially adjacent space and which define two kinds of compartment - open at the top - each compartment extending in the space over the upflow tube and in said radially adjacent space, one kind of compartment consisting of risers which have no bottoms in the space over the upflow tube and which do have bottoms in said radially adjacent space, whereas the other kind of compartment consists of downcomers which do have bottoms in the space over the upflow tube and have no bottoms in said radially adjacent space, the design being such that a riser and a downcomer are always side by side and have one partition in common.

Thus, essentially the top edges of all the partitions together function as the overflow edge. The liquid ascends from the upflow tube into a riser compartment between the two partitions forming the riser. The liquid is then present not only in the part of the riser that is located in the space over the upflow tube - and has no bottom - but also in the other part of the riser which is located in the radially adjacent space in areas where there is a bottom.

The liquid may flow over the edge of one of the two partitions that form the riser into a neighbouring downcomer compartment. There are two possibilities here, namely:

- a) the liquid flows over the partition directly above the upflow tube and then plunges from the part of the riser over the upflow tube into that part of a downcomer which is likewise located over the upflow tube, and which at that location has a bottom, whereupon the liquid flows along this bottom in the downcomer concerned to that part of the downcomer which is located next to the space over the upflow

tube, which part has no bottom, whereupon the liquid flows into the part of the separator hood next to the upflow tube (i.e. below the partition), subsequently leaving the separator hood via the liquid outlet;

5 b) the liquid flows over the partition next to the space over the upflow tube and then plunges from the part of the riser next to the space over the upflow tube into the part of a downcomer which is located next to the space over the upflow tube, which downcomer has no bottom at that location, so that the liquid can flow directly into the  
10 space of the separator hood next to the upflow tube (i.e. below the partitions), subsequently leaving the separator hood via the liquid outlet.

With the apparatus according to the invention the liquid at the top of the upflow tube and in the risers will generally show some  
15 foam formation and have a lower specific gravity than that in the downcomer. The liquid level in the riser will almost come to the upper edges of the partitions, whereas the liquid level in that part of the downcomer which is located next to the space over the upflow tube will in most cases have fallen to below the partitions, i.e.  
20 remain below the top edge of the upflow tube. It will, however, be clear that the whole situation will also depend on the surface area of the passages in riser and downcomer and on the rate of discharge via the liquid outlet, as well as on the level control, if any.

According to the invention the partitions traverse the space  
25 directly above the upflow tube and the space next to it. The risers have bottoms in the space next to the space over the upflow tube and the downcomers have bottoms in the space over the upflow tube. The bottoms will therefore be fitted both to the partitions and to the upflow tube. This construction will prevent any liquid flowing from the upflow tube direct  
30 into a downcomer and from a riser direct into the space next to the upflow tube. Thus the liquid is invariably forced to flow over the edge of a partition, which edge thus actually acquires the function of an overflow edge.

By installing a greater number of partitions, which also increases the  
35 number of risers and downcomers, the overall length of the overflow edge

is increased. It will be clear that the overflow edge can be made many times longer than it is when the top of the upflow tube itself is used as (circular) overflow edge. The number of partitions is limited by the consideration that, to have some effect in the separation  
5 of gas and liquid, the compartments must have a certain minimum width.

According to a preferred embodiment of the invention all the partitions have horizontal top edges and all these top edges lie in one plane. This embodiment will usually be chosen because it is the simplest one to fabricate and has the advantage that all parts of the  
10 overflow edge are equally functional. However, it is possible to depart from this embodiment and yet to retain at least part of the advantages of the invention.

According to the invention the partitions are preferably placed in a radial position. This construction is preferred especially when  
15 upflow tube and separator hood have a circular cross-section, which will certainly be the case when an elevated pressure is used in the upflow tube. A radial position of the partitions has the advantage that all the risers and/or downcomers can be identical and can be equally spaced around the circumference of the upflow tube, so that the risers  
20 and the downcomers, respectively, are all equally loaded.

A disadvantage of the radial position of the partitions is that the compartments will not be equally wide everywhere. It is also possible for instance to place the partitions parallel, but then special  
25 measures have to be taken on two sides of the separator hood, where the partitions cannot traverse both the space over the upflow tube and the space next to it.

When the partitions are placed radially it may be preferable not to have them extend over the upflow tube as far as the produced centre line of the upflow tube. If they do, the compartments narrow  
30 down to a wedge shape. There is not much space there for the partitions and, moreover, the top of each compartment near this point will contribute only little to the separation of gas and liquid: the two partitions of a compartment come too close together there, so that the width of the compartment becomes too small there.

35 When, as indicated hereinabove, the partitions do not extend as far

as the produced centre line of the upflow tube, then, according to the invention, each partition is preferably connected, over the upflow tube, with the ends of the two neighbouring partitions by a lateral partition. Thus, there will be some measure of structural rigidity in the compartments and, in the case of the downcomers, the lateral partition may function as overflow edge for the liquid coming up centrally through the upflow tube. The lateral partitions of the downcomers will be attached with their lower edges to the bottoms of the downcomers; whilst the upper edges of these lateral partitions may be level with the upper edges of the radial partitions. Unless this is undesirable for structural reasons, the lateral partitions of the risers may be omitted; they do not contribute to the overall length of the overflow edge.

In particular when the phases to be separated also contain solids, for instance in the case of a slurry reactor for hydrocarbons, where the phase to be separated from the gas phase comprises the hydrocarbons themselves or an auxiliary liquid with solid catalyst particles, but also in other cases where no dead corners can be allowed in the separator hood (in which corners the residence time of a phase may for instance become unacceptably long), each bottom, according to the invention, preferably slopes downwards in the direction of that part of the upflow tube wall which is located under the compartment belonging to that bottom. For the bottom of the riser, which is located in the space next to the space over the upflow tube, this means that it slopes down inwards, and for the bottom of the downcomer, which is located in the space over the upflow tube, that it slopes down outwards. Obviously, to save material, the lower edges of the partitions may, if desired, be adapted to this particular construction of the bottoms.

Preferably - in particular when a relatively large quantity of liquid has to be separated from the gas - in the case of a radial position, the two partitions forming a riser include an angle of less than  $15^{\circ}$  and the two partitions forming a downcomer include an angle of more than  $15^{\circ}$ .

According to another embodiment of the invention, which has advantages for instance when a relatively small quantity of liquid has to

be separated from a gas phase, the two partitions forming a riser include an angle of more than  $15^{\circ}$  and the two partitions forming a downcomer include an angle of less than  $15^{\circ}$ .

5 It will be clear that, when the partitions are placed radially and riser and downcomer have equal angles, the surface areas of the passages in riser and downcomer are determined by the diameters of the upflow tube and the separator hood (provided that the partitions traverse both the space over the upflow tube and the space next to it). Now, in order to keep the diameter of the separator hood as small as possible, it is  
10 advisable to make the angle included by the partitions forming a downcomer compartment large with respect to the angle included by the partitions forming a riser compartment. On the other hand, the overall length of the overflow edge decreases when the total number of compartments decreases. In addition, the ratio between the passage of the  
15 riser and that of the downcomer must not deviate too much from the value dictated by the ratio between the quantities of gas and liquid to be separated, because if it does, space will be lost. A total number of twelve risers and twelve downcomers has been found to be a good compromise; a riser and a neighbouring downcomer will then together occupy an  
20 angle of  $30^{\circ}$ .

According to an embodiment of the invention the partitions extend as far as the wall of the separator hood. In this way a simple construction is obtained. The separator hood then forms the required back wall of the riser compartments; whilst the partitions and the bottoms can be attached  
25 to the separator hood. However, it is pointed out that more complicated embodiments are possible. Thus, in each riser according to the above embodiment a strip of the bottom adjacent to the separator hood may be omitted, whilst at the location where the bottoms do begin the partitions of each riser are connected by a lateral partition. In this way additional  
30 downcomers are formed which are entirely located next to the space over the upflow tube, the overflow edge being formed by these lateral partitions.

According to a particular embodiment of the invention, which is pre-eminently suitable for use in slurry reactors, the bottoms make an  
35 angle with the horizontal plane. This embodiment has special advantages



when the liquid contains solid particles, such as a catalyst.

The invention also relates to a slurry reactor comprising a reactor vessel constructed as an upflow tube as well as a separator hood on the reactor vessel into which the reactor vessel opens via an overflow edge, which separator hood has a gas outlet above the overflow edge and a liquid outlet below the overflow edge, but outside the reactor vessel, which liquid outlet is connected via a cooling device placed outside the reactor vessel to the bottom of the reactor vessel, which bottom is also fitted with a gas inlet. The construction of the separator hood with overflow edge is in accordance with one of the above-mentioned embodiments of the invention. Such a slurry reactor is suitable for synthesizing a product that is liquid under the synthesis conditions by catalytic conversion of a gas in the presence of a recycled product containing a catalyst. The recycled liquid with the catalyst, together with the gas, is passed upwards through the reactor; in the separator hood the unconverted gas, together with gaseous reaction products is separated from the liquid containing the catalyst, which liquid is cooled outside the reactor and subsequently recycled to the bottom of the reactor. Part of the liquid is carried off as product.

Another application of the slurry reactor is the one in which from a gas a gaseous product is synthesized with the aid of a catalyst suspended in a recirculating auxiliary liquid. The gases are then separated from the auxiliary liquid. Alternatives to the two above-mentioned applications of the slurry reactor are, for instance, those in which the external cooling of the liquid separated from the gas is omitted, in which the separated liquid is not recycled or in which during the separation the catalyst is left in the reactor.

The liquid discharge facilities in the separator hood preferably comprise at least four discharge lines equally spaced around the circumference of the separator hood, each connected to the bottom of the reactor via a separate heat exchanger. This embodiment is pre-eminently suitable for use in the synthesis of one or more hydrocarbons from a gas containing hydrogen and carbon monoxide. In this "Fischer-Tropsch" synthesis a considerable amount of heat is generated in the reactor, which heat can be efficiently removed in the way indicated above.

The invention will now be further elucidated with reference to the accompanying drawing.

In the drawing, Fig. 1 is a schematic longitudinal section through a slurry reactor with separator hood in accordance with an embodiment of the invention.

Fig. 2 is a cross-section, on a larger scale, according to line I-I in Fig. 1.

Fig. 3 shows a schematic perspective of part of the interior of the separator hood according to Figs. 1 and 2.

Fig. 4 shows a schematic perspective of the part of the interior of a separator hood corresponding to that of Fig. 3 according to another embodiment of the invention.

With reference to Fig. 1, first a short description will be given of the principle of the slurry reactor according to an embodiment of the invention.

The slurry reactor, 1, is constructed as an upflow tube, i.e. in the vertical reactor vessel 1 a liquid phase - containing catalyst particles - and a gaseous phase flow upwards. The upper edge, 2, of the reactor vessel 1 has been cut off straight, so the upper edge, 2, is circular and lies in a horizontal plane.

On top of and around the upper part of reactor vessel 1 a separator hood has been fitted, the diameter of the separator hood being larger than that of reactor vessel 1. The top of hood 3 is closed by a cover, 4, with a central gas outlet 5. The underside of hood 3 is located beside upper edge 2 of vessel 1 and is constructed as a bottom, 6, sloping down inwards. This bottom 6 has outlets to four liquid discharge pipes 7, two of which are visible in the drawing.

In the space directly above upflow tube 1 and in the space next to it, hood 3 has a system of partitions - to be further described hereinafter with reference to Figs. 2 and 3 - which together generate a system of overflow edges lying in the horizontal plane 8 through the upper edges of the vertical partitions 9, which upper edges themselves are also overflow edges. The liquid and the gas flow from vessel 1 between certain pairs of vertical partitions 9 upwards to plane 8, where the liquid plunges over the overflow edges and flows

1117442

between other pairs of vertical partitions downwards into annular space 10 under plane 8 next to the space directly above reactor 1. From annular space 10 the liquid flows down through discharge pipes 7 to heat exchangers 11 and from there to the bottom 12 of reactor 1 via pipes 13.

The gas phase which is separated from the liquid during overflow of the liquid in hood 3 collects in space 14 above plane 8 and is removed from it via outlet 5. At the bottom 12 of reactor 1 fresh gas is supplied via inlet tube 15.

With this slurry reactor it is possible to synthesize, for instance, a hydrocarbon from synthesis gas containing  $H_2$  and CO supplied via tube 15, by passing liquid product in which the catalyst required for the synthesis is suspended, together with the gas, upwards through reactor 1, by separating the unconverted gas and the gaseous reaction products in hood 3 from the liquid containing catalyst and discharging it via tube 5, by recycling product and catalyst via tube 7, heat exchanger 11 and tube 13 to the bottom 12 of the reactor - meanwhile cooling product and catalyst in exchanger 11 - and by discharging excess product and any catalyst to be regenerated via discharge nozzle 16 from hood 3. In the synthesis of hydrocarbons external cooling is often desirable because of the highly exothermic character of the reactions.

With reference to Figs. 2 and 3 a further description will now be given of the construction of the system of partitions in hood 3 of the apparatus according to Fig. 1.

As is seen from the top view of Fig. 2, the vertical partitions 9 have been placed radially in hood 3 in a particular manner. They extend in plane 8 from the wall of hood 3 to a cylindrical opening 17 which is in the centre of hood 3. Partitions 9 form neighbouring pairs including a smaller and a larger angle, respectively ( $10^\circ$  and  $20^\circ$ , respectively).

Upper edges 18 of partitions 9 in plane 8 form overflow edges (see Fig. 3). Between two neighbouring partitions 9 making an angle of  $10^\circ$  a bottom 19 is present between the wall of hood 3 and upper edge 2 of upflow tube 1, which bottom slopes down inwards because it adjoins the wall of hood 3 at the level of plane 8, i.e. at the level of upper edges 18 of vertical partitions 9, whereas it adjoins

upper edge 2 of upflow tube 1 some distance below this plane 8. Bottom 19 ends at edge 2, i.e. between the vertical partitions referred to there is no bottom in the space over tube 1.

Between two neighbouring partitions 9 making an angle of  $20^\circ$  a bottom 20 is present in the space over tube 1, which bottom extends upwards from upper edge 2 of tube 1 to cylinder 17. The bottom begins at the level of upper edge 2 and ends at cylinder 17, some distance below plane 8, in an edge 21. From edge 21 a lateral partition 22 rises vertically to plane 8, i.e. to the level of the upper edges 18 of partitions 9. Bottoms 20 are located in the space over upflow tube 1, so they do not extend into the space next to it. Bottoms 19 and 20 as well as partitions 22 have been welded in place between partitions 9.

This means that two kinds of compartment have been formed between partitions 9, viz.:

- 15 - riser compartments between partitions 9 which include an angle of  $10^\circ$ , which riser compartments are open at the bottom in the space over upflow tube 1 and closed at the bottom in the space next to it (bottoms 19).
- downcomer compartments between partitions 9 which include an angle of  $20^\circ$ , which downcomer compartments are closed at the bottom in the space over upflow tube 1 (bottoms 20) and open at the bottom in the space next to it. Moreover, in the space over upflow tube 1 the downcomer compartments, when viewed in a radial direction, are closed at the inside (lateral partitions 22).

The operation of the system of partitions and bottoms described and depicted is as follows:

In Fig. 3 three compartments are shown in perspective, of which the foremost is a riser compartment, the middle one a downcomer compartment and the hindmost a riser compartment again.

The liquid phase and the gas phase flow from reactor 1 between partitions 9 of the riser compartments and in the space inside the circle of lateral partitions 22 upwards to overflow edges 18 and 23. As the phases flow over these edges a separation takes place, the gas being removed in an upward direction while the liquid flows down in the downcomer compartments between partitions 9 and 22, eventually arriving in space 10 beside reactor 1 and flowing downwards from there.

# 1117442

Owing to the special shape of the riser compartments -- which widen upwards -- an expanding mass of foam in hood 3 can be coped with: whilst owing to the sloping position of bottoms 19 and 20 there are no dead corners in which catalyst particles can stay behind.

5 Fig. 4 shows a greatly simplified embodiment of the construction according to Fig. 3. Two riser compartments are visible, which are bounded by radial partitions 24 and 25 and by radial partitions 26 and 27, respectively. Between partitions 25 and 26 there is a downcomer compartment.

10 Wall 28 of the reactor ends at the top in a horizontal circular edge 29 to which bottoms 30, 31 and 32, of a riser, a downcomer and a riser, respectively, have been connected by welding. The bottoms are all in one plane, the plane through edge 29 and through the lower edges of partitions 24 up to and including 27.

15 Bottoms 31 tapers off to a point in the centre where the partitions meet. Bottoms 30 and 32 extend from edge 29 to wall 33 of the separator hood.

20 The top edges of partitions 24 up to and including 27 lie in one horizontal plane and form overflow edges. Above this plane, inside wall 33, is the gas-collecting space, below the plane between walls 28 and 33 is the liquid discharge space.

THE EMBODIMENTS OF THE INVENTION IN WHICH AN EXCLUSIVE PROPERTY OR PRIVILEGE IS CLAIMED ARE DEFINED AS FOLLOWS:

1. An apparatus for separating gas and liquid, comprising a central upflow tube which at the top opens, via an overflow edge, into a separator hood fitted over and around the top of the upflow tube and containing a wall and having a gas outlet above the overflow edge and a liquid outlet below the overflow edge, but outside the upflow tube, characterized in that the overflow edge is formed by a system of partitions which traverse the space directly above the upflow tube and continue in the radially adjacent space and which define two kinds of compartment - open at the top - each compartment extending in the space over the upflow tube and in said radially adjacent space, one kind of compartment consisting of risers which have no bottoms in the space over the upflow tube and which do have bottoms in said radially adjacent space, whereas the other kind of compartment consists of downcomers which do have bottoms in the space over the upflow tube and have no bottoms in said radially adjacent space, the design being such that a riser and a downcomer are always side by side and have one partition in common.
2. An apparatus according to claim 1, characterized in that all the partitions have horizontal upper edges and that all these upper edges lie in one plane.
3. An apparatus according to claim 1, characterized in that the partitions are placed in a radial position.
4. An apparatus according to claim 3, characterized in that over the upflow tube the partitions do not extend as far as the produced centre line of the upflow tube.
5. An apparatus according to claim 4, characterized in that the end of each partition is connected over the upflow tube with the ends of the two neighbouring partitions by a lateral partition.
6. An apparatus according to claim 1, 2 or 3, characterized in that

each bottom slopes downwards in the direction of that part of the upflow tube wall which is located under the compartment belonging to that bottom.

7. An apparatus according to claim 3, characterized in that the two partitions forming a riser include an angle of less than  $15^{\circ}$  and that the two partitions forming a downcomer include an angle of more than  $15^{\circ}$ .

8. An apparatus according to claim 3, characterized in that the two partitions forming a riser include an angle of more than  $15^{\circ}$  and that the two partitions forming a downcomer include an angle of less than  $15^{\circ}$ .

9. An apparatus according to claim 1, 2 or 3, characterized in that the partitions extend as far as the wall of the separator hood.

10. A slurry reactor comprising a reactor vessel constructed as an upflow tube containing a bottom as well as a separator hood on the reactor vessel into which the reactor vessel opens via an overflow edge, which separator hood has a gas outlet above the overflow edge and a liquid outlet below the overflow edge, but outside the reactor vessel, which liquid outlet is connected, via a cooling device placed outside the reactor vessel, to the bottom of the reactor vessel, which bottom is also fitted with a gas inlet, characterized in that the construction of the separator hood with overflow edge is in accordance with claim 1.

11. A slurry reactor according to claim 10, characterized in that the liquid outlet comprise at least four discharge lines equally spaced around the circumference of the separator hood, each connected to the bottom of the reactor via a separate cooling device.

12. A process for synthesizing a gaseous or liquid product by catalytic conversion of a gas in the presence of a catalyst in liquid product or an auxiliary liquid, comprising: providing a reactor vessel having a central upflow tube which at the top opens, via an overflow edge, into a separator hood fitted over and around the top of the upflow tube and having a gas outlet above the overflow edge and a liquid outlet below the overflow edge, but

outside the upflow tube, characterized in that the overflow edge is formed by a system of partitions which traverse the space directly above the upflow tube and continue in the space next to it and which divide the space in the separator hood directly above the upflow tube and the space next to it into two kinds of compartment - open at the top - each compartment extending in the space over the upflow tube and in the space next to it, one kind of compartment consisting of risers which have no bottoms in the space over the upflow tube and which do have bottoms in the space next to it, whereas the other kind of compartment consists of downcomers which do have bottoms in the space over the upflow tube and have no bottoms in the space next to it, the design being such that a riser and a downcomer are always side by side and have one partition in common;

passing said gas and liquid upwardly within the upflow tube;

separating said gaseous product from said liquid by means of said overflow edge and removing the gaseous product via said gas outlet;

withdrawing the separated liquid from the separator hood; and

cooling said separated liquid and returning it to the lower end of the upflow tube to be mixed with an incoming supply of said gas.

13. A process according to claim 12 for synthesizing a product that is liquid under the synthesis conditions, wherein the recycled liquid contains a catalyst.

14. A process according to claim 13, characterized in that one or more hydrocarbons are synthesized from a gas containing hydrogen and carbon monoxide.

SMART & BIGGAR  
OTTAWA, CANADA

PATENT AGENTS



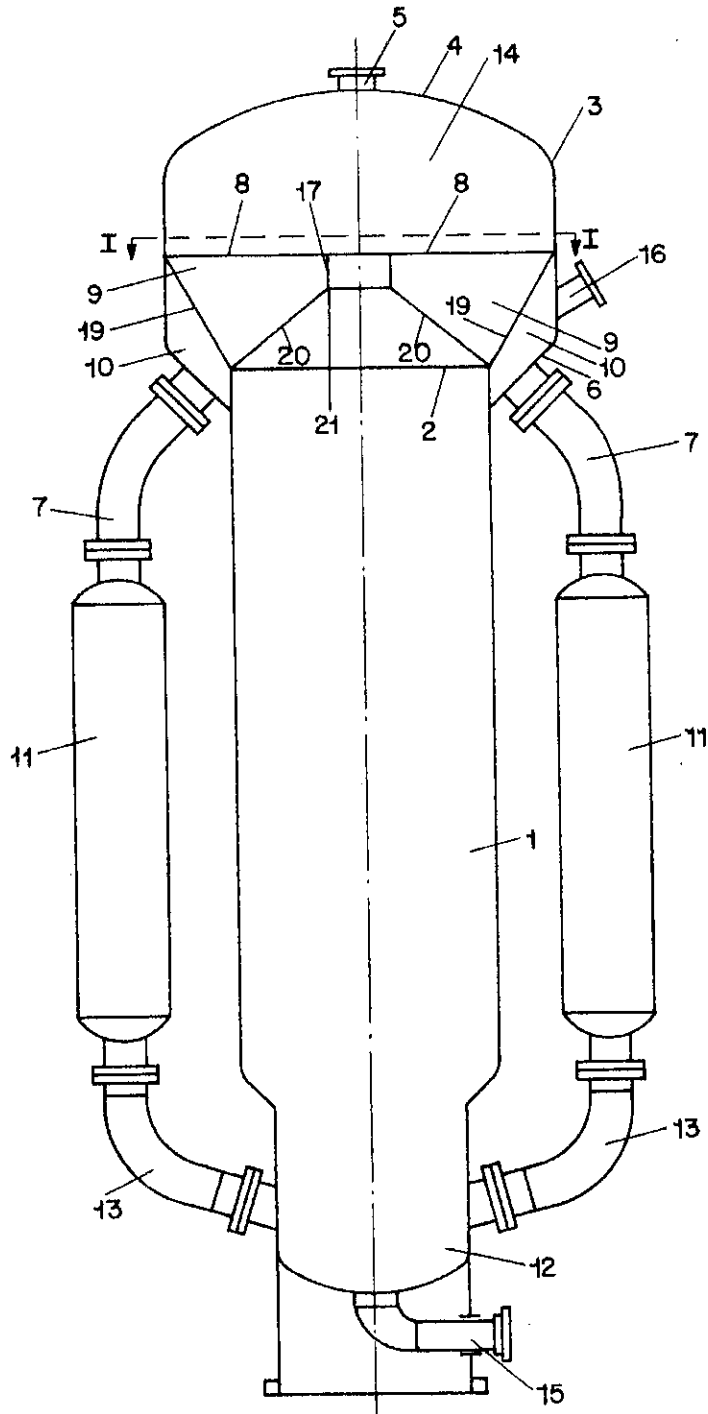

FIG. 1

PATENT AGENTS  
*Smart & Riggan*

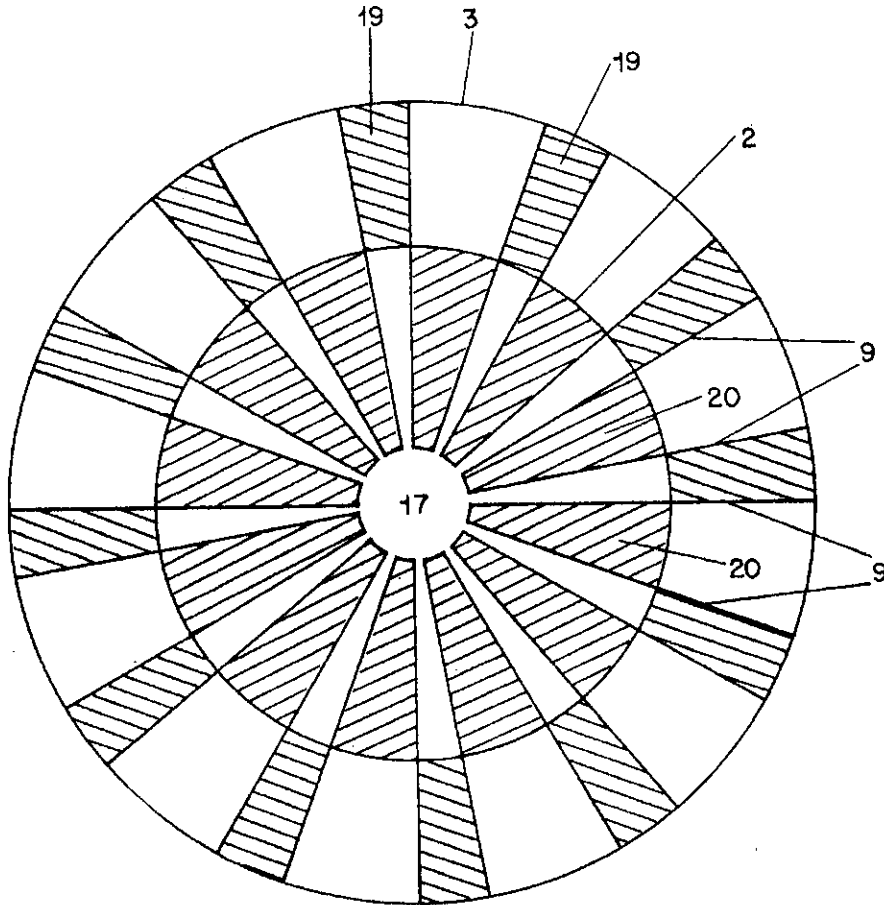

FIG. 2

PATENT AGENTS  
*Adman & Biggar*

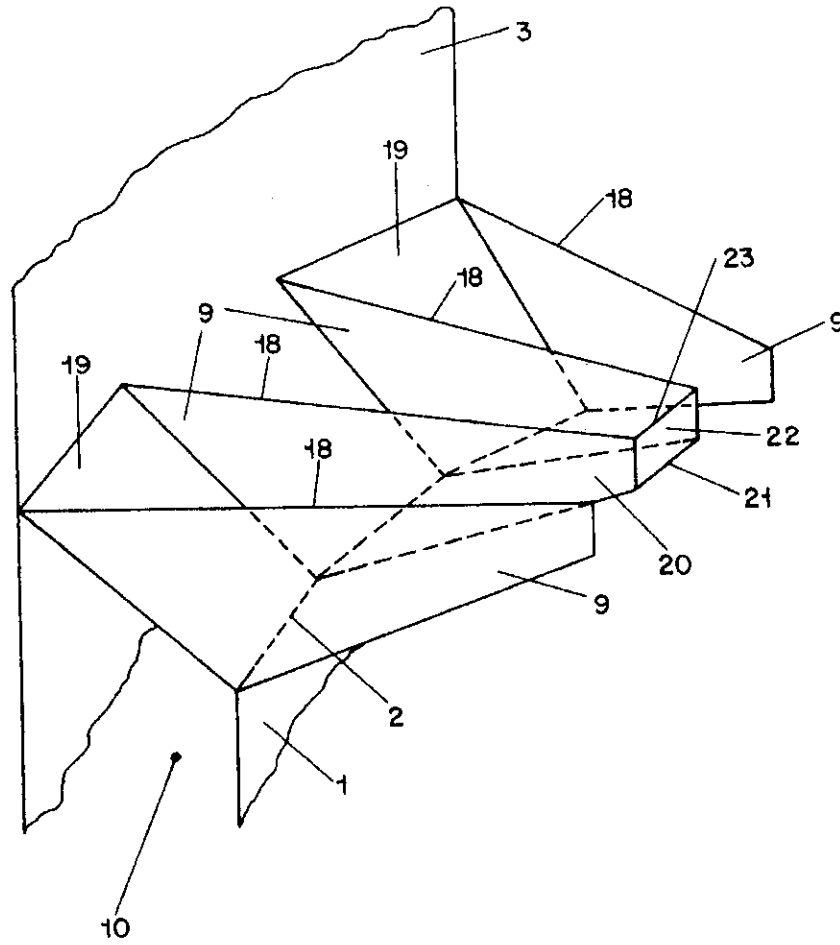

FIG. 3

PATENT AGENTS  
*Adman & Biggar*

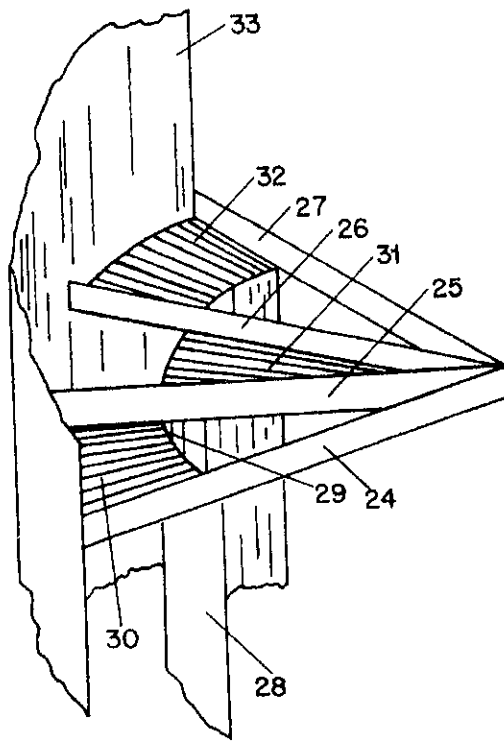

FIG. 4

PATENT AGENTS  
*Amant & Riggar*