

Appendix D

Case 4

Texaco Gasifier and Sour Gas Shift Converter

CASE 4

The following report gives a brief description of each of the units in the block flow diagram. All capital cost data in this report, except where otherwise specified, has been estimated from similar installations described in the Houston Area Medium-BTU Coal Gasification Project Final Report, published in June 1982 by Union Carbide [1] (All references to material in this report will be referred to as Houston, and all scaling exponents from the Houston report are 0.65). The plant consumes 1.3 million metric tons of coal, 1.1 million metric tons of oxygen, and produces 0.50 million metric tons of mixed alcohols per year.

COAL PREPARATION

Coal (stream 10) and water (stream 12), are sent to the Coal Preparation Block. The coal is crushed, mixed with the water, and pumped to the gasifier as a ~60% solids mixture by weight (stream 13). The Coal Preparation Block is composed of four plants from the Houston report. Plant 01 is the Coal Slurry Preparation Plant. The cost of this plant was scaled linearly due to its multiple train format; where each train can handle up to 1,150 tons of coal per day. Plant 61 is the Reclaiming, Transfer, and Crushing Plant. The cost of this plant was scaled exponentially. Plant 22 is the Barge Terminal. This plant was scaled exponentially. Plant 60 is Coal Receiving and Storage and again the cost for this plant was scaled exponentially.

TEXACO GASIFIER

The coal slurry (stream 13) is mixed with compressed oxygen (stream 9) and burned at 1,200-1,400°C and 8,000 kPa in the Texaco Gasifier Block. The hot, raw gas (stream 8) is sent to the Syngas Heat Recovery Block, and the slag (stream 33) is sent to the Slag Handling Block. The equivalent of the Texaco Gasifier Block is Plant 03 in the Houston report, and each train can handle up to 958.3 tons of coal per day.

CRYOGENIC OXYGEN PLANT

Compressed air (stream 1) is cooled and sent to the Cryogenic Oxygen Plant Block, and is separated into high purity oxygen (stream 2), nitrogen (stream 3), argon (stream 6), and a water and carbon dioxide waste mixture (stream 28). A small quantity of nitrogen (stream 19) is sent to the Rectisol Block. The Cryogenic Oxygen Plant Block does not include the inlet air compressors or the outlet oxygen compressors. In the cryogenic system, there are provisions for gaseous and liquid oxygen backups sufficient to maintain downstream plant operation in the event of a shutdown in the cryogenic facility. We also assume that some scale down is possible for this system, so the capital investment has been calculated linearly for the reduction in trains, and exponentially for throughput reduction per train. Each train can produce up to 2,000 tons of oxygen per day. The Houston plants that comprise the Cryoplant Block are 02 and 08.

RECTISOL

The cooled raw gas stream (stream 18), nitrogen gas (stream 19) for methanol regeneration, and methanol make-up (stream 20) for vapor loss all enter the Rectisol Block. H_2S levels are reduced to the ppb range and CO_2 levels to the ppm range. The clean syngas (stream 22) is sent to the alcohol synthesis loop. A CO_2-N_2 mixture (stream 24) and a CO_2 rich stream (stream 23) are produced as byproducts. Condensed water is also removed (stream 17A). This block is the same as Houston Plant 05. The cost for this plant was estimated by using exponential scaling.

SLAG HANDLING

Molten slag from the Texaco Gasifier Block (stream 33) is direct quenched with water and sent to slag disposal (stream 37). A small amount of water (stream 36) is purged from the closed loop and is replaced by water make-up (stream 34). This block is the same as Houston Plant 63. The cost for this plant was estimated by exponential scaling.

COS HYDROLYSIS

The sulfide rich stream from the Rectisol Block (stream 25) and steam are sent to the COS Hydrolysis Block where COS is converted to H₂S. The product gas (stream 41) is sent to the Claus Sulfur Recovery Block. The COS Hydrolysis Block cost is assumed to be negligible.

SYNGAS HEAT RECOVERY

The raw gas stream from the Texaco Gasifier Block (stream 8) at 1,300°C and 8,000 kPa enters the Syngas Heat Recovery Block and is cooled against process boiler feed water at 25°C (stream 71). The raw gas stream exits at 300°C (stream 18), and the boiler feed exits as steam at 10,000 kPa and 535°C (stream 68). It is assumed that the raw gas stream is cooled further prior to entering the Rectisol Block. This block is part of Houston Plant 04.

CLAUS PLANT

Hydrogen sulfide rich gas (stream 41) is mixed with air (stream 42) and converted in a two-step reaction to elemental sulfur (stream 46). The unreacted hydrogen sulfide (stream 45) is then sent to the Beavon Plant for further treatment. This block is the same as Houston Plant 06. The cost for this plant was estimated by exponential scaling.

BEAVON PLANT

The Claus tail gas (stream 45) and air (stream 47) go to the Beavon Block. Additional sulfur is made (stream 51), and the gas leaving (stream 50) is sufficiently free from sulfides that it can be vented to the atmosphere. A sour water stream (stream 54) is sent from the plant for treatment. The cost of this block was estimated from data collected from various sources, with a scaling exponent of 0.65 [2].

MoS₂ ALCOHOL SYNTHESIS LOOP

Clean syngas (stream 26) at 140 atmospheres enters the catalytic reactor along with the syngas recycle (stream 56B). The products (stream 26A) are taken to the separations block where the unreacted syngas is removed (stream 59). Part of this stream (stream 27) is sent to power generation while the rest (stream 56) is sent to CO₂ removal. The cost of this block was estimated from the cost of a methanol synthesis loop, with a scaling exponent of 0.565 [3].

CO₂ REMOVAL

This block is very similar to the Rectisol Block. Recycled gas from the alcohol separation block (stream 56) is the only feed. CO₂ free syngas (stream 56A) is then recompressed and sent back to the reactor. CO₂ is taken off as a product (stream 57). The cost of this block is calculated the same way as in the Rectisol block. Its power requirement is included in the Rectisol block.

COMBUSTION GAS TURBINE

The light hydrocarbons extracted from the reactor recycle (stream 27) in the Alcohol Synthesis Loop are sent to a combustion gas turbine with hot gas heat recovery. The power from the combustion gas turbines is assumed to be 35% of the HHV of the fuel in stream 27. This is consistent with recent studies on IGCC plants using medium BTU synthesis gas [7]. The cost for this block was estimated from data taken from an EPRI report, where each train can produce up to 200 MW with a scaling exponent of 0.67 [8].

EXHAUST GAS HEAT RECOVERY

The hot exhaust gas stream from the Gas Turbine Block (stream 70) at 590°C and 101 kPa enters the Exhaust Gas Heat Recovery Block and is cooled against process boiler feed water at 25°C (stream 73). The exhaust gas stream exits at 200°C (stream 75), and the boiler feed exits as steam at 10,000 kPa and 535°C (stream 74). The cost for this block was estimated from data taken from an EPRI report, where each train can generate up to 425 tons of steam per hour with a scaling exponent of 0.67 [8]. This block also supplies the reheat between the high pressure and intermediate pressure steam turbines.

POWER GENERATION

The steam from the Syngas Heat Recovery Block and the Exhaust Gas Heat Recovery Block is let down in the steam turbines for power production. The cost for this block was estimated from data taken from an EPRI report, where each train can produce up to 500 MW with a scaling exponent of 0.67 [8]. This is a 3-stage steam turbine system. The high pressure stage inlet is 535°C, 10,000 kPa steam. The exhaust at 3,000 kPa is reheated to 535°C before entering the intermediate pressure stage. The final stage exhausts to a surface condenser at 7.4 kPa. Each turbine has an assumed efficiency of 75%.

SOUR GAS SHIFT CONVERTER

Raw fuel gas (stream 8A) leaving the Heat Recovery Block is shifted to produce the desired H₂ to CO ratio needed in the alcohol synthesis reactor.

IMPORTANT POINTS OF INFORMATION

Several decisions were made for the creation of this case that should be outlined. Also, there are alternatives that have not been fully considered which will be considered in more detail later. They are listed below along with the reasons behind them.

- The traditional method for purifying high quantities of pure oxygen is by cryogenics, which is used for this case. However, recent reports suggest that membrane and catalytic processes are becoming economically competitive with cryogenics. Therefore, we will examine these alternatives.
- The Rectisol system was chosen for this system for H₂S and CO₂ removal. The major alternative to Rectisol is Selexol. The literature indicates that Rectisol has a higher installed capital cost, but a lower fixed operating cost than Selexol. Both of these systems are capable of removing H₂S to the ppm level and beyond. However, there is some evidence that quantities of H₂S are beneficial if the reaction involves the MoS₂ catalyst. If this is so, then a system such as the Benfield acid gas removal process might be more suitable. The Benfield system does not remove as much H₂S and has lower capital and operating costs.
- The operating pressure for the Texaco gasifiers has been set at 8,000 kPa. This is the highest pressure indicated in the literature at which a Texaco gasifier has been run. Since the pressure required at the reactor is 14,000 kPa, we would of course like to run the gasifiers at as high a pressure as possible.

TOTAL ESTIMATED CAPITAL INVESTMENT (MM\$)

Sour Gas Shift	4.4
Coal Preparation	51.4
Texaco Gasifier	195.9
Slag Handling	3.7
Gas Turbines	45.1
Steam Turbines	25.4
Exhaust Gas Heat Recovery	8.9
Synthesis Gas Heat Recovery	5.6
Cryogenic Oxygen Production	109.0
Rectisol (Acid Gas Separation)	51.3
Claus (Sulfur Recovery)	12.5
Beavon	2.7
Alcohol Synthesis Loop	47.2
CO2 Removal	26.9
Other Compressors	60.4
TOTAL	650.3

(sum of individual block costs does not exactly equal the total due to round-off)

OVERALL ECONOMIC EVALUATION

The following table gives the totals and breakdowns for the yearly operating costs as well as the total installed cost for the plant.

TOTAL ESTIMATED INSTALLED CAPITAL COST (MM\$)	650.3
TOTAL ESTIMATED OPERATING COSTS (MM\$/YR)	157.8
Coal (\$33/metric ton delivered)	43.2
Other Expenses	114.6
TOTAL ESTIMATED CREDITS (EXCLUDING ALCOHOLS) (MM\$/YR)	51.8
Power (\$0.05/kWh)	41.7
Slag (\$5.5/metric ton) [5]	0.8
Sulfur (\$300/metric ton) [6]	9.3

Credits for nitrogen, argon, and other rare gases have not been included because prices were not available and potential markets have not yet been identified.

STAND ALONE COMPRESSORS AND POWER SUMMARY

There are 4 compressors that are not included in any of the blocks. Their inlet, outlet, pressure change, power rating, and installed capital cost are listed below. Following that is a summary of the total plant power output/input [4]. An efficiency of 70% is assumed for all compressors, with a maximum pressure ratio of 5 for a single stage of compression. Multiple compression stages with intercooling are used for services with pressure ratios greater than 5.

FUNCTION	INLET STREAM	P (kPa)	OUTLET STREAM	P (kPa)	POWER (MW)	COST (MM\$)
Air Prep	1A	101	1	500	-42.3	37.4
O2 Prep	2	500	9	8136	-14.7	12.9
Rxtr Prep	22	8030	26	14000	-7.2	6.4
Recy Comp	56A	12666	56B	14000	-3.6	3.6
Total compressor needs					-67.8	
Other in plant needs					-15.2	
Total produced in steam and gas turbines					187.1	
Net power output					104.2	
Total installed compressor costs (1992 dollars)						60.4

REFERENCES

1. *Final Report on the Houston Area Medium-BTU Coal Gasification Project, Volumes 2 and 3*. Prepared by the Linde Division of Union Carbide Corporation, June 1982.
2. "Beavon Sulfur Removal Process," *Hydrocarbon Processing*, April 1984, p.78.
3. Frank, Marshall E. "Methanol: Emerging Uses, New Syntheses," *Chemtech*, June 1982, pp. 358-362.
4. Baasel, William D., *Preliminary Chemical Engineering Plant Design, 2nd edition*, Van Nostrand Reinhold, New York, 1990, pp. 529-530.
5. T. Torries, personal communication
6. *Chemical Marketing Reporter*, August 31, 1992.
7. Report TR-101789, Houston Lighting and Power Company's Evaluation of Coal Gasification Coproduction Energy Facilities, EPRI Project 3226-04, 1992.
8. EPRI Report TR-100319, *Evaluation of a 510-MWe Destec GCC Power Plant Fueled With Illinois No. 6 Coal*, Prepared by Fluor Daniel, Inc., EPRI Project 2733-12, 1992.

Figure D.1 : Block Flow Diagram for Case 4

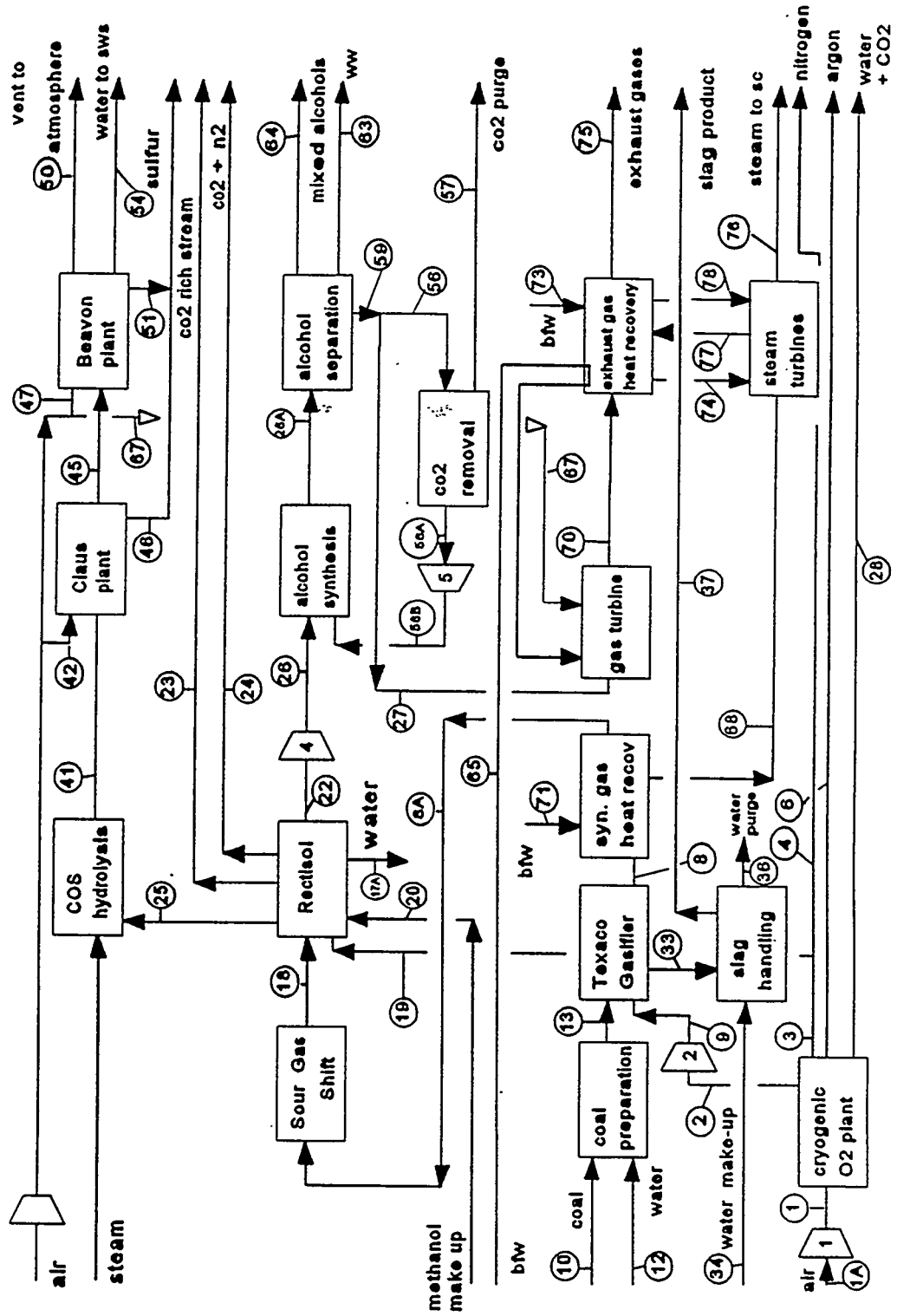

Table D.1 Case 4 Flow Tables

	001	001A	002	003	004	006	008	8a	009
Ar	193.6	193.6				193.6			
C									
CH3OH									
C2H5OH									
C3H7OH									
C4H9OH									
C5H11OH									
CO						6481.0	6481.0		
CO2	6.7	6.7				2529.1	2529.1		
COS						12.1	12.1		
CaCO3									
H2							4958.2	4958.2	
H2O	500.4	500.4					4209.6	4209.6	
H2S							109.3	109.3	
N2	16212.5	16212.5		16212.5	15780.1		73.7	73.7	
NH3							12.3	12.3	
O2	4358.6	4358.6	4358.6						4358.6
S									
Al2O3									
C3H6O2									
C4H8O2									
CH4							7.8	7.8	
C2H6									
kmol/hr	21271.9	21271.9	4358.6	16212.5	15780.1	193.6	18393.1	18393.1	4358.6
kg/hr	610474.5	610474.5	139476.8	453951.3	441843.2	7744.0	385273.2	385273.2	139476.8
Temp. (C)	25.0	25.0	25.0	25.0	25.0	25.0	1300.0	300.0	225.0
Press. (KPA)	500.0	101.3	500.0	500.0	500.0	500.0	8135.8	8106.0	8135.8

Table D.1 Case 4 Flow Tables (cont'd)

	010	012	013	017A	018	019	020	022	023
Ar									
C	9029.9		9029.9						
CH3OH							1.7		
C2H6O									
C3H8O									
CAH100									
C5H12O									
CO					5382.1			5382.1	2089.1
CO2					3628.0				
COS					12.1				
CaCO3									
H2	3689.9		3689.9		6057.1			6057.1	
H2O	104.0	5517.2	5621.2	3110.8	3110.8				
H2S					109.3				
N2	79.9		79.9		73.7	432.4			
NH3					12.3				
O2	711.1		711.1						
S	121.3		121.3						
A12O3	169.1		169.1						
C3H6O2									
CAH8O2									
CH4					7.8			7.8	
C2H6									
kmol/hr	13905.2	5517.2	19422.5	3110.8	18393.1	432.4	1.7	11447.0	2089.1
kg/hr	163731.0	99310.4	263041.5	55993.5	385273.2	12108.1	53.0	162937.5	91918.8
Temp. (C)	25.0	25.0	25.0	25.0	300.0	25.0	25.0	25.0	25.0
Press. (KPA)	101.3	101.3	8135.8	8030.0	8030.0	500.0	101.3	8030.0	8030.0

Table D.1 Case 4 Flow Tables (cont'd)

	024	025	026	026A	027	028	033	034	036
Ar									
C									
CH3OH		1.7		628.3					
C2H6O				655.4					
C3H8O				145.0					
C4H10O				36.5					
C5H12O				15.2					
CO			5382.1	7001.9	714.2				
CO2	1269.8	269.1		1493.7	152.4	6.7			
COS		12.1							
CaCO3									
H2			6057.1	7880.0	803.8				
H2O				140.1		500.4		10446.2	10446.2
H2S		109.3							
N2	506.2								
NH3		12.3							
O2									
S									
Al2O3							169.1		
C3H6O2				18.0					
C4H8O2				11.9					
CH4			7.8	4400.9	448.9				
C2H6				171.6	17.5				
kmol/hr	1775.9	404.4	11447.0	22598.6	2136.7	507.1	169.1	10446.2	10446.2
kg/hr	70042.7	16541.9	162937.5	421000.0	36016.1	9302.4	17245.0	188032.2	188032.2
Temp. (C)	25.0	25.0	100.0	310.0	25.0	25.0	1300.0	25.0	25.0
Press. (KPA)	8030.0	8030.0	14000.0	12666.0	12666.0	500.0	101.3	101.3	101.3

Table D.1 Case 4 Flow Tables (cont'd)

	037	041	042	045	046	047	050	051	054
Ar									
C									
CH3OH		1.7		1.7			1.7		
C2H6O									
C3H8O									
C4H10O									
C5H12O									
CO									
CO2		281.2		281.2			281.2		
COS									
CaCO3									
H2									
H2O				115.3					121.3
H2S		121.3		6.1					
N2			216.8	216.8			250.8		
NH3		12.3		12.3					12.3
O2			57.6				6.0		
S					115.3			6.1	
Al2O3	169.1								
C3H6O2									
C4H8O2									
CH4									
C2H6									
kmol/hr	169.1	416.5	274.5	633.3	115.3	43.0	539.6	6.1	133.7
kg/hr	17245.0	16758.9	7915.2	20985.4	3688.7	1239.1	19637.0	194.1	2393.4
Temp. (C)	25.0	25.0	25.0	200.0	125.0	25.0	100.0	125.0	50.0
Press. (KPA)	101.3	101.3	101.3	101.3	101.3	101.3	101.3	101.3	101.3

Table D.1 Case 4 Flow Tables (cont'd)

	056	056A	056B	057	059	063	064	065	067
Ar									
C									
CH3OH							628.3		
C2H6O							655.4		
C3H8O							145.0		
C4H10O							36.5		
C5H12O							15.2		
CO	6287.7	6287.7	6287.7		7001.9				
CO2	1341.4			1341.4	1493.7				
COS									
CaCO3									
H2	7076.3	7076.3	7076.3		7880.0				
H2O						140.1		967.2	
H2S									
N2									20421.9
NH3									
O2									
S									5428.6
A12O3									
C3H6O2									
C4H8O2						18.0			
CH4	3952.0	3952.0	3952.0		4400.9	11.9			
C2H6	154.1	154.1	154.1		171.6				
kmol/hr	18811.4	17470.0	17470.0	1341.4	20948.1	170.1	1480.4	967.2	25850.5
kg/hr	317082.8	258062.4	258062.4	59020.4	353098.9	4905.1	62996.0	17408.8	745529.1
Temp. (C)	25.0	25.0	45.0	25.0	25.0	25.0	25.0	25.0	25.0
Press. (KPA)	12666.0	12666.0	14000.0	12666.0	12666.0	12666.0	12666.0	10000.0	101.3

Table D.1 Case 4 Flow Tables (cont'd)

	068	070	071	073	074	075	076	077	078
Ar									
C									
CH3OH									
C2H6O									
C3H8O									
C4H10O									
C5H12O									
CO						1350.4			
CO2		1350.4							
COS									
CaCO3									
H2									
H2O	14422.0	2721.2	14422.0	3079.4	3079.4	2721.2	17501.5	17501.5	17501.5
H2S									
N2		20421.9				20421.9			
NH3									
O2		3710.6				3710.6			
S									
Al2O3									
C3H6O2									
C4H8O2									
CH4									
C2H6									
kmol/hr	14422.0	28204.2	14422.0	3079.4	3079.4	28204.2	17501.5	17501.5	17501.5
kg/hr	259596.7	798954.0	259596.7	55430.1	55430.1	798954.0	315026.7	315026.7	315026.7
Temp. (C)	535.0	590.0	25.0	25.0	535.0	200.0	40.0	380.0	535.0
Press. (KPA)	10000.0	101.3	10000.0	10000.0	10000.0	101.3	7.4	3000.0	3000.0

Table D.2 Case 4 Energy Analysis

ELECTRICITY		
Plant	Electricity Used (MW)	Electricity Produced (MW)
Coal Preparation Plant	2.7	0.0
Cryogenic Oxygen Plant	5.8	0.0
Rectisol Plant	4.2	0.0
Texaco Gasifier	0.8	0.0
Syn. Gas Heat Recovery	1.2	0.0
Claus Plant	0.5	0.0
Gas Turbine	0.0	80.9
Steam Turbine	0.0	106.2
Compressor 1	42.3	0.0
Compressor 2	14.7	0.0
Compressor 4	7.2	0.0
Compressor 5	3.6	0.0
Total	82.9	187.1