

Characterization and Optimization of Sorbents Utilized for Emission Control During Gasification

Quarterly Report
January 1 - March 31, 1997

By:
Dr. Ziaul Huque
Dr. Daniel Mei
Dr. Jianren Zhou

RECEIVED
JAN 28 1998
OSTI

Work Performed Under Contract No.: DE-FG21-74MC31426

For
U.S. Department of Energy
Office of Fossil Energy
Federal Energy Technology Center
Morgantown Site
P.O. Box 880
Morgantown, West Virginia 26507-0880

By
Prairie View A&M University
Mechanical Engineering
College of Engineering and Architecture
P.O. Box 397
Prairie View, Texas 77446-0397

MASTER

df
DISTRIBUTION OF THIS DOCUMENT IS UNLIMITED

Summary of research activities performed at PV A&M U and research plan in Q1 97

- The automatic data acquisition system successfully passed testing for automatic measurement on electrical signals and pressure sensor outputs. Completed interfacing different instruments with the computer via RS 232 and IEEE 488 communications on data acquisition system. Completed a user's manual prepared for test programming, test data analysis and results presentation..
- Continued the survey on one time disposable metal oxides as a sorbent substitute.
- The most promising features of using these one time disposable oxides are listed below.
 - The metal oxides can be brought to farther upstream during gasification or combustion process to provide metal oxides with more time in reacting with SO₂, H₂S and other chemicals to maximize desulfurization operation.
 - The cost of these disposable metal oxides can be economical enough to make IGCC and PFBC feasible economically in the future.
 - The size distribution of candidate metal oxides can be controlled within certain range to optimize the dust cake removal during back pulse dust cake cleaning.
 - The discharged ash and metal oxides would cause unexpected environmental safety issues.
- The size distribution controls of metal oxides will play a very important role for using the disposable type of metal oxides in the Hot Gas Cleanup program.
- Based on the permeability characterization of ceramic candle filters, conducted at Prairie View A&M University, Daniel Mei and Ziaul Huque found out that the permeability of the used filter varies axially and circumferentially after operation in particulate filtration vessel.
- Pv A&MU is in the process of testing filters fabricated by different manufacturers to characterize filter permeability variations to further study the feasibility of using disposable metal oxides as an economical sorbent substitute.
- According to the permeability variation distributions on filter, samples of the external filter surface of these sections with low permeability were analyzed in the material laboratory. The low permeability sections displayed with deposits of foreign materials and chemical residuals. These deposition of fine size particles sintered at high temperature with time might be the cause that decreased the original high permeability distribution of the unused filter.
- If the size of particulate distribution can be adjusted within certain range to facilitate the forming of proper dust cake without sacrificing gas filtering and dust cake removal, then the metal oxides can be easily controlled within the specified band range to optimize Hot Gas Cleanup in both dust cake removal and sorbent pricing reduction.

USER'S MANUAL

FOR

AUTOMATIC TEST SYSTEM

FOR FETC PROJECT

Table of Contents

Section 1	General Information	page 3
Section 2	Installation	page 3
Section 3	Programming	page 3
Section 4	Operation of the test system	page 4
Appendix	Documentation of test program and subvi	page 5

Section 1 - General Information

The automatic test system is an integration of high quality instrumentations, meters, a micro-processor controlled pressure controller and temperature chamber, a set of sophisticated data acquisition system, advanced software package and well experienced testing technology.

The automatic test system can be a multi-purpose testing facility to calibrate, test sensors and characterize the pressure field and flow conditions contained in a pressure vessel.

The test system can be expanded with minimum cost by pre-selected communication arrangement, GPIB-488 and RS-485, to integrate the current setup to a more versatile system.

Section 2 - Installation

The software work of the automatic test system had been completed. The hardware will be installed at the laboratory of mechanical engineering at PV A&MU in Q2, 1997.

Section 3 - Programming

3.1 General description of test programming

The programming software utilized for the test station is based on LabVIEW data acquisition package purchased from National Instruments.

The main test program is developed with the aid of using subvis feature structure of LabVIEW, programmed with lower layers of subvis. All of the vis had been installed in the PC (personal computers). The user's manual is prepared such that the user should be able to follow step by step to use and/or modify the vis already installed in the PC.

3.2 Detail description of the test programming

A sample test programming, named as CALBTEST, is documented as a pressure sensor calibrating testing prior to the use of pressure sensors to monitor the pressure field and pressure variations during the test work of FETC project.

The main test program, CALBTEST, is a five point pressure testing program performed at 25.0, 0.0, 70.0, 0.0 and 25 degree C. There are four groups of five point pressure testing and data acquisition performed for each temperature level. Temperature is first set at the beginning of each test subgroup. The procedures of the adjustment required for each temperature profile and its duration for parts soaking in the temperature chamber/oven are well defined in each temperature vis. The procedures for pressure level adjustment are also described on different pressure vis. Parameters and procedures for the data acquisition vis are also well defined in its corresponding

vis.

The most difficult part of work for the integration of the system is the design layout and the communication interface between LabVIEW and each equipment. Temperature chamber/oven is connected to LabVIEW via RS-485 to provide multi-chamber connection under the control of a single PC in the future. All the other equipment is interfaced with LabVIEW via GPIB 488 to maximize the flexibility and the speed of communications. The speed matching of commands communication between PC and equipment micro-processors are adjusted by providing proper waiting time during the command sending cycles, otherwise error messages will be displayed even with proper programming.

The supporting vis for CALBTEST include temperature, datascan, DAQ basic, and pressure controller vis. All the subvis and the vis and LabVIEW functions related to the programming are attached in the Appendix for reference.

Section 4 - Operation of the test system

The hardware connections will be started in Q2, 1997. Prior to each test run, make sure the channel number between the sensors to be tested and the LabVIEW vis input are matching. National Instruments SCXI assembly and its DAQ system is capable to acquire and output the test data to EXCEL spread sheet.

APPENDIX

Documentation of Test Program and Subvi

Time waited prior to room temp testing.

0

Time waited prior to cold temp testing.

0

Time waited prior to hot temp testing.

0

Time waited prior to room temp testing.

0

8 [0..12]

Perform the 3rd 5-point pressure testing and data acquisition at hot temperature.

DATA
SCAN

9 [0..12]

Set the temperature back to room temperature, 25 degree C. If your room temperature is different than 25 degree C and/or the holding time is less than 75 minutes, please adjust the Temproom.vi accordingly.

TEMP
room

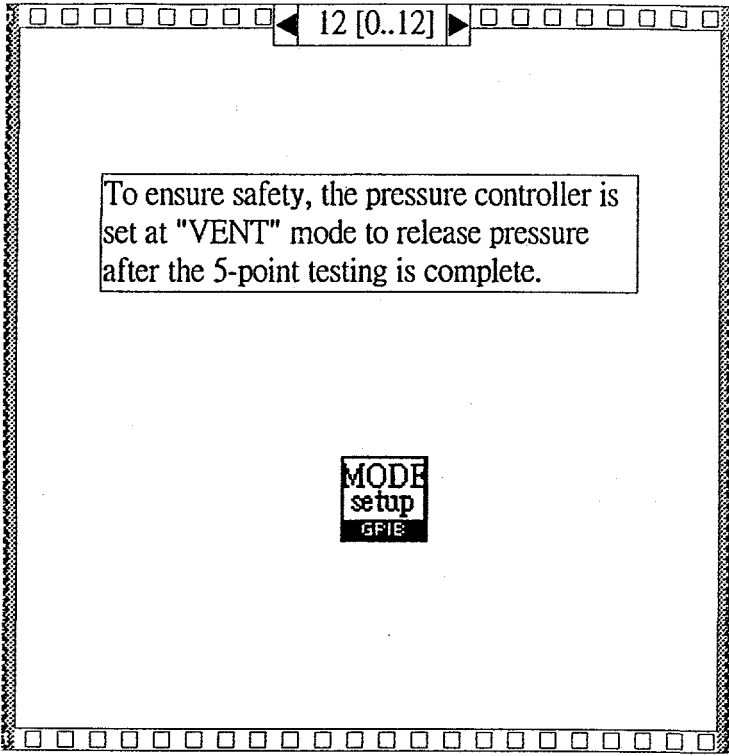

Time req'd to stabilize loproess (2sec) upward

0.00

Time req'd to stabilize middle pressure (2 sec) upward

0.00

Time req'd to stabilize high pressure (2 sec) peak point

0.00

Time req'd to stabilize middle press (2 sec) downward

0.00

Time req'd to stabilize loproess (2sec) downward

0.00

0 [0..14]

Set up the low pressure level

The first test pressure point

The pressure is upward



This is a 5-point pressure test daq vi example

Please modify the vi if test points are more than 5

Create more pressure setup vis and add more sequence frames as required

1 [0..14]

Time needed shall be adjusted as required

Time req'd to stabilize lpress (2sec) upward

This is an example to set waiting time = 2 sec



All setup time req'd in this vi is 2 sec for demo only

◀ 2 [0..14] ▶

Perform daq after low pressure is stabilized

DAQ
basic

Make sure the channel no. matches the setup no.

◀ 3 [0..14] ▶

Set up the middle pressure level

The 2nd test pressure point

The pressure is upward

mdlps
15psig
6718

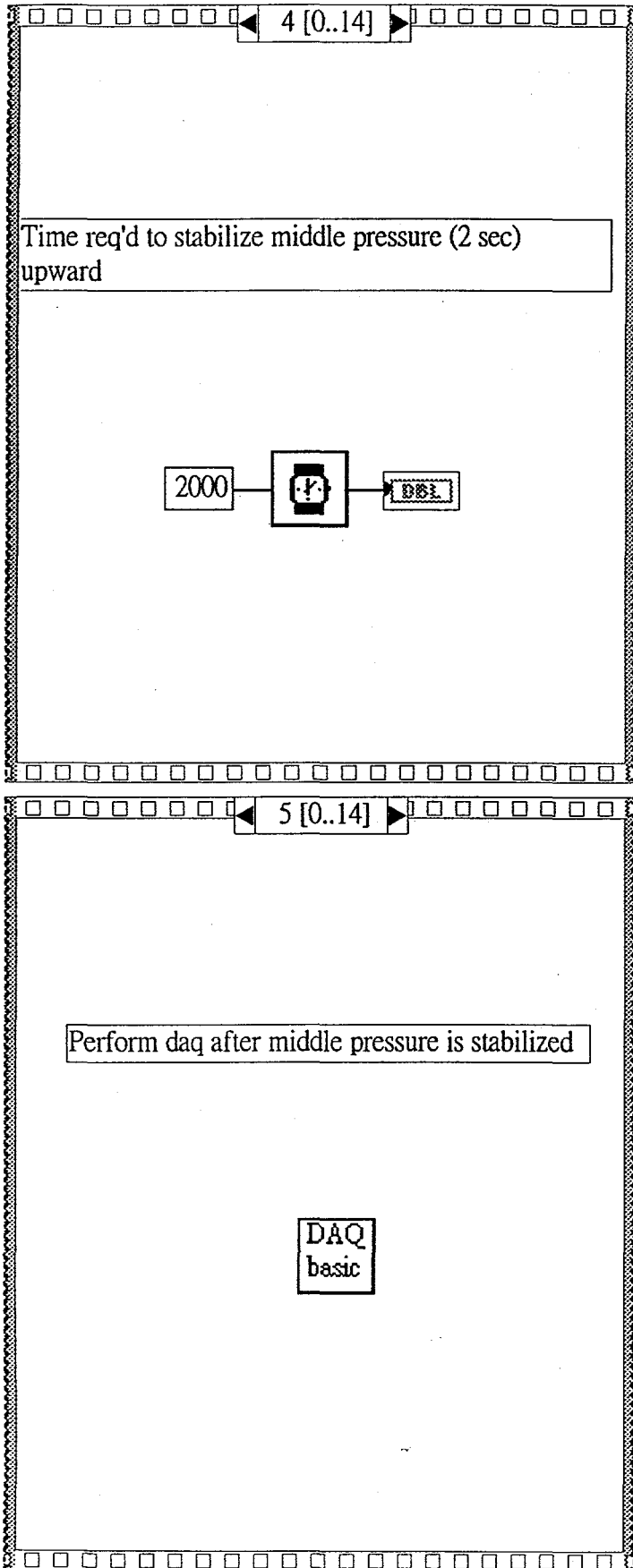

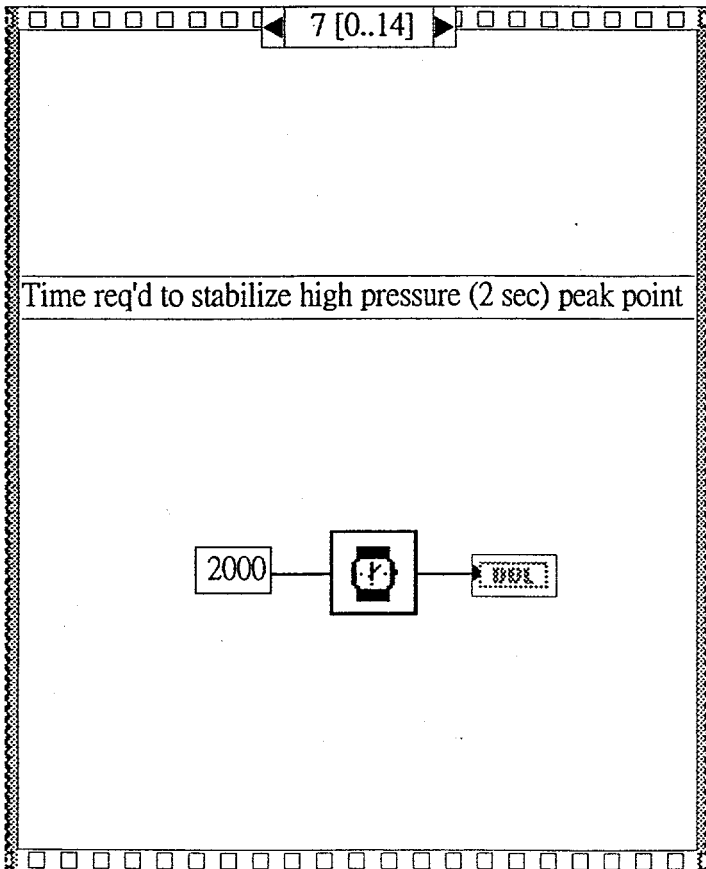
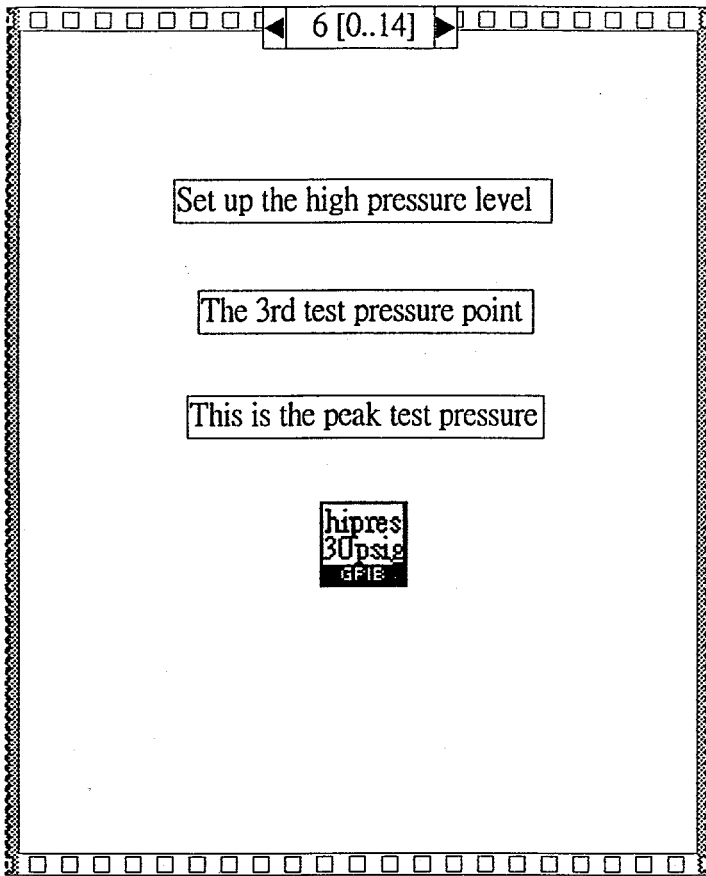

8 [0..14]

Perform daq after high pressure is stabilized

DAQ
basic

9 [0..14]

Set up the middle pressure level

The 4th test pressure point

The pressure is downward

mdlps
1.5psig
GFIE

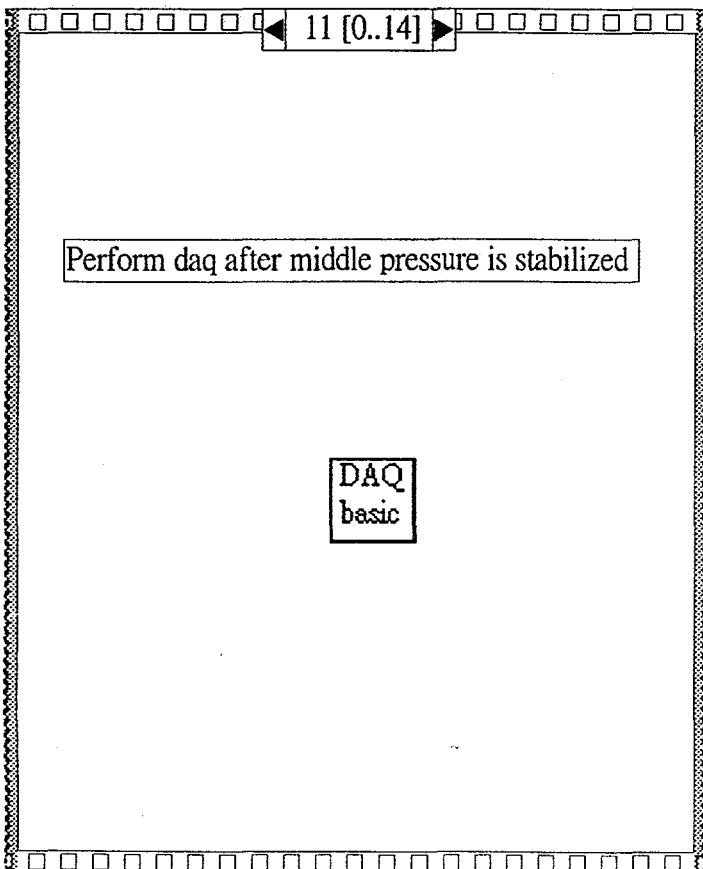
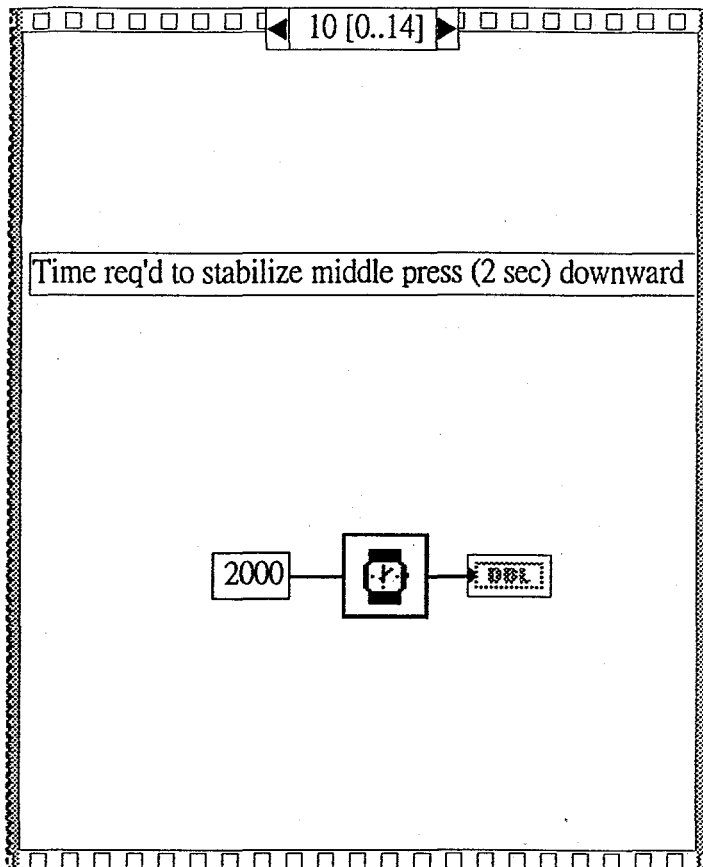

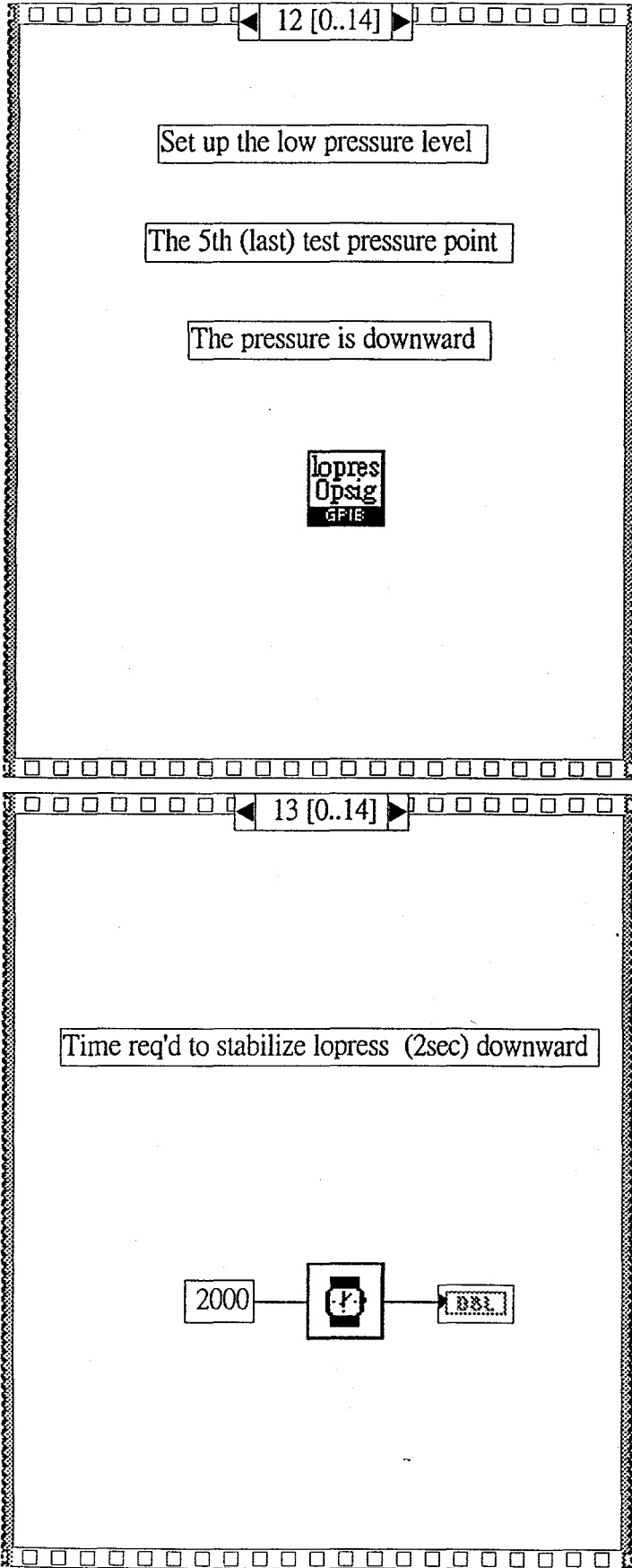

14 [0..14]

Perform daq after low pressure is stabilized

This is the last daq performed for the 5-point testing

DAQ
basic

The image shows a screenshot of a LabVIEW front panel window. The window title bar at the top reads "14 [0..14]". Inside the window, there are two text boxes. The first text box contains the text "Perform daq after low pressure is stabilized". The second text box, located below the first, contains the text "This is the last daq performed for the 5-point testing". In the center of the window, there is a square icon with the text "DAQ" on the top line and "basic" on the bottom line. The window has a decorative border consisting of a series of small squares.

GPIB address

2

Set point

30.00

Units Text

psig

GPIB Error



device 1	sample 0	0.00	File Path c:\resu
channel OB0!SC!!MD2!0:11	0.00	0.00	Format
loops 2	0.00	0.00	Delimite
high limit 0.20	0.00	0.00	Append? ON
low limit -0.20	0.00	0.00	Transpose OFF
delay in sec 1.00	0.00	0.00	

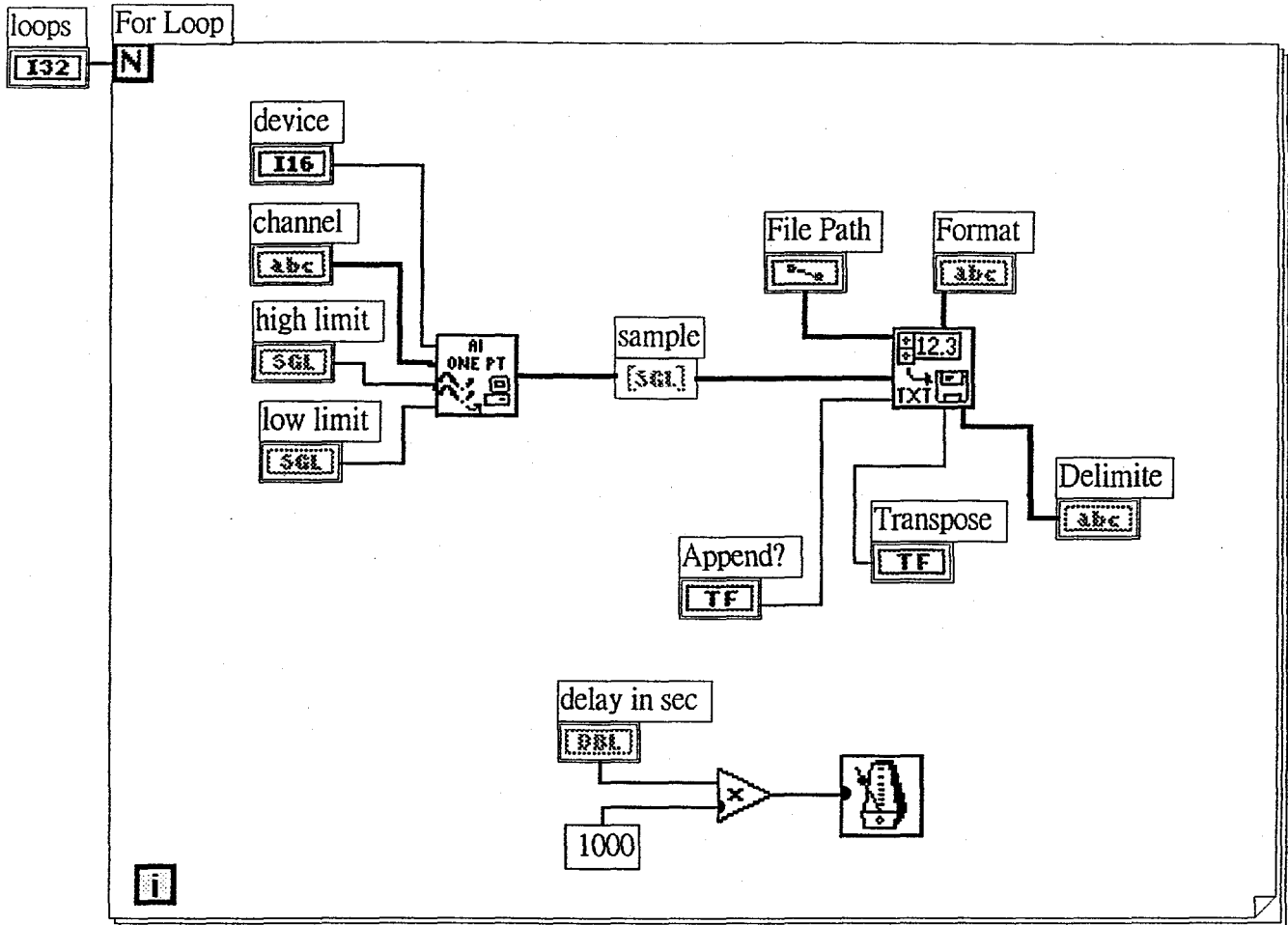

No of total commands ▲▼ 0

▲▼ 6

NOTE: The number of total commands must be equal to the number of the command strings you programmed. The command string is fed into Thermotron control in series, one string each loop.

Delay time sec

▲▼ 1.00

NOTE: You have to slow down the input speed of each command string, otherwise the controller is not fast enough to accept your instructions; and error message will display.

Command string list

#A01S\r\n
#A01LPM1,3,V\r\n
#A01LPI0,70\r\n
#A01LPI1,70,,,0,5\r\n
#A01LPI2,70,,,0,30\r\n
#A01LPI0\r\n

NOTE: The communication between LabVIEW vi to Thermotron temperature controller is via RS-485 serial port. The port number assigned for this system is port number 5.

- Programming Instructions -

#01 is the prefix of each command string. 01 is the channel number one, which is for the chamber temperature control; 02 is for humidity control which is not available in this chamber design. At the end of each command string, use \r\n to terminate the command string. At the end of the last command string, use \n to terminate the string. To ensure adequate temperature profile control, the first command instruction string "S" (upper case) is served to terminate previous temperature profile to allow a new temperature profile input according to the command strings followed. The last string is to instruct the controller to "RUN" the above command instruction strings. LPI is the programming instruction, and the sequence of each string is numbered from 0,1,2,3, etc as required. LPM1,3,V instructs the controller that there are up to 3 command strings, with value instructions. LPI0,70 set the initial temperature to 70 degree C. LPI2,70,,,0,30 sets the holding time period of 70 degree C to 0 hour 30 minutes. If you need 1 hr and 20 minutes holding time, change instruction to LPI2,70,,,1,20. Adjust each temperature holding time as required to saturate parts in the temperature chamber. Please check the programming manual for details, this is a programming demo.

No of total commands

116

